

# 17

OERSTED

THE BEGINNINGS OF ELECTROMAGNETISM

(Blue Book pp. 82-87)

Additional Notes and Amendments

I. Historical.....	1
II. Oersted's Experiments.....	7
III. Laboratory Experiments.....	11
IV. Apparatus.....	13
V. Bibliography.....	16

Appendix: Reproductions of Oersted's announcements  
of 1820:

First page of original Latin version.....	18
English translation in Annals of Philosophy.....	19

Samuel Devons  
July 1975  
Barnard-Columbia History  
of Physics Laboratory

## OERSTED

### THE BEGINNINGS OF ELECTROMAGNETISM

(Blue Book pp. 82-87)

#### Additional Notes and Amendments

##### I. Historical

A length of wire, an electric current, and a commonplace magnetic compass: all that Oersted required to make his momentous discovery! Why then was there a lapse of twenty years between Volta's invention of the pile (1800) and the discovery of the magnetic influence of the galvanic current (1820)? Certainly not lack of technical resources, which had been available for many years. Voltaic piles powerful enough to fuse and decompose sizeable quantities of alkali halides into the constituents sodium, potassium, chlorine and bromine; to excite brilliant electric arcs; to raise strips of platinum to white heat had been used in elaborate electrical experiments years before the discovery of the simple magnetic effects. Nor was the "received knowledge" of the time hostile to the notion of some intimate connection between electricity and magnetism. On the contrary, it was very much in the spirit of the day to seek connections between the different "forces" of Nature; and electricity with its known diversity of mechanical, chemical, physiological, thermal and visual effects had amply demonstrated that this faith in the interconnectedness of all Nature was not misplaced. Nor indeed was there any lack of attempts to discover, nor of claims - some going back long before Volta, others more recent - to have observed or to have discovered by deliberate experiment some actual relationship between the two phenomena. But none - until Oersted's demonstration - were given much credence, or were even capable of reproduction. But with Oersted's discovery, recognition was instantaneous; within days his observations were reproduced in all the scientific centers in Europe, and within weeks they were rapidly extended. Whatever had delayed the discovery, by 1820 the time was ripe!

One cannot explain this twenty-year lapse; but to appreciate the manner and the significance of Oersted's discovery, one can examine both the influence of the scientific climate of the time and also the more particular ingredients of Oersted's success, and the failure of the others before him. Unless we do this, Oersted's experiments are likely to appear trivial; and any reproduction of them not only trivial, but wholly misrepresentative of Oersted's accomplishment.

Electricity and magnetism had been clearly distinguished and separated back in 1600 by William Gilbert. At the time this was a major step forward, and thenceforth the two "sciences" independently developed - for some two centuries. By the latter part of the 18th century, largely under the powerful and all-pervasive influence of Newtonian principles, formal analogies between the two phenomena - the inverse-square law applied, or was made to apply to both - began to evoke serious reconsideration of possible physical connections between them: i.e. between magnetism, natural or artificial, and the ordinary electricity of charges and electroscopes, and of sparks and shocks. Franz Aepinus (1724-1802) based his important theory (1759) of electrical forces and matter on the analogy between the processes of electrification and magnetization; Charles Coulomb's celebrated experiments (1785-88) on electricity immediately followed his investigations of a similar character with magnetism. The full title of the prize competition set by the Electoral Academy of Bavaria:

"Is there a Real and Physical Analogy between Electric and Magnetic Forces; and if such exist, in what Manner do these Forces Act upon the Animal Body?"

is quite expressive of the state of knowledge - and ignorance - of the time. One of the prizes went to Jan Hendrick van Swinden (1746-1823), professor of Natural Philosophy and Mathematics at Amsterdam. From his wide knowledge of, and contributions to both fields - especially terrestrial magnetism - he concluded that the analogy was apparent, rather than real, in the physical sense; but others who competed for the prize expressed the contrary belief, - that so close (!) a formal analogy indicated a single underlying physical agent.

On the whole circumspection prevailed - at least on the part of the more experienced and distinguished natural philosophers; and their skepticism was increased rather than diminished by the reports and claims of observed connections between electricity and magnetism. The most authentic were, perhaps, the reports such as those of Benjamin Franklin of lightning disturbing compass needles; and the electrical discharge of the Leyden jar magnetising an iron wire. But Franklin himself leaned toward the view that these were secondary effects (such as heating); and the influence of his views was quite powerful. But one of his most active followers - Father Giovanni Battista Beccaria (1716-1781), professor at Turin, and one especially active in the study of atmospheric electricity, was sufficiently convinced of a direct connection,

to propose that the "sign" of the electricity in the thunder-cloud could be ascertained from the magnetic polarity acquired by an iron body struck by its lightning discharge! Similar claims were made in respect to electrical discharges produced by giant electrical machines.

Refinements in the construction of magnetic compass needles had led, by the late eighteenth century, to an instrument of considerable sensitivity, and with it the temptation to use, or misuse, its delicacy to detect some elusive "force". Thomas Milner, in 1783, reports the deflection of the compass needle by ordinary electricity; Coulomb was troubled by what he believed to be electrification in his magnetic measurements. But an interaction between compass needle and electricity cannot be equated to one between electricity and magnetism - as Gilbert so clearly showed with his 'versorium' in 1600. But this lesson, like others which Gilbert expounded, were apt to be forgotten in the succeeding centuries!

All in all, the attempts to relate "ordinary electricity" with magnetism were not taken too seriously and had little influence: either the circumstances were too complex and ephemeral to be properly assessed, or the results too uncertain to generate systematic and fruitful inquiry. In the absence of compelling evidence, skepticism continued to prevail.

To us, it would seem that the advent of the pile and the new style of electrical experimentation with continuous currents, must have completely changed the whole complexion of the problem. It did, but not at once; and manifestly the changed circumstances were not recognized. Not the least reason for this was that the pile, qua pile - a generator of current (galvanic electricity) with a substantial tension (a potential-difference of 50, 100 or more volts) was neither essential nor really suitable for driving a substantial current through a metallic wire. But the pile was the symbol - par-excellence - of the new electricity, and the problem was to find the connection between electricity and magnetism. (Not until after Oersted was the issue formulated as a connection between electric current and magnetism!) How perfectly natural, if one is to experiment with electricity, to ensure that its presence is demonstrable and unambiguous. Electricity means electroscopes and shocks - the multi-element pile produces just these. So we see in one of the earliest (1802), and most frequently championed, claims to have observed electric-magnetic interactions - that of Gian Domenico Romagnosi (1761-1835), a professor of Law at the University of Parma! - it is already the familiar pile, à la Volta, that is used. Numerous discs, lots of

electricity - but, alas! negligible current: discs, at most a few inches in diameter could certainly not deliver anything like the current (something on the order of one ampere at least!) needed to give noticeable deflections of the compass needle. In fact Romagnosi did not seem to have used a deliberately closed circuit at all!

Why should he have done so? Connecting the poles of the pile with a metallic conductor would have removed the very indications that electricity was present ("discharged the pile") and rendered success highly implausible! If Romagnosi did observe some deflection it might have been electrostatic in origin - it certainly could not have been magnetic.

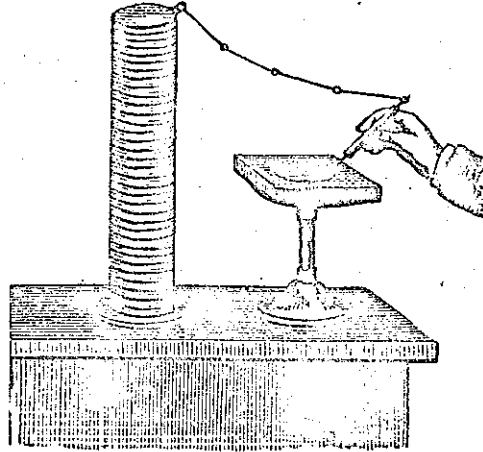

Romagnosi's experiment: Contact between one "pole" of the pile and the compass needle resulted in deflection of the latter. (After Fahie)(1)

The natural appeal of the pile - one of a hundred cups - likewise featured in the experiments of one Guisepe Mojon - a learned chemist of Genoa - who seems to have emulated with galvanic electricity Franklin's experiments on the magnetization of needles by discharge of Leyden jars. Several stages further removed from reality were the claims inspired by the unrestrained imagination and enthusiasm of young Bavarian Johann Wilhelm Ritter (1776-1810), the discoverer of the secondary voltaic pile (the forerunner of the storage battery). Ritter's pile consisted of a series of metal discs, all of the same metal, with the usual moist pads interposed between each disc and the successive one. The extremities of this pile were connected to the terminals of a conventional voltaic pile, so that a current flowed for some time. When the "charging" pile is removed, the new Ritter-pile is found to be electrified: it could give sparks, shocks and decompose water. So much was real. But Ritter did not stop here. Observing, correctly, that his metallic discs had become "galvanized", he was lured by the mystique of polarity to a comparison between them and magnetized iron. By "galvanizing" a gold needle, pivoted like a compass or dip-needle, he found that it would assume a definite orientation or inclination, and it was the positive pole that dipped. The extension from the secondary to the primary pile (Volta's "contact-electricity")

was for Ritter an obvious next step: he announced "...that a needle composed of silver and zinc arranged itself in the magnetic meridian and was slightly attracted and repelled by the poles of a magnet"(2).

A more sober attempt to pursue the "pole" analogy was made in 1805 in Paris by the experienced Jean N. P. Hachette (1769-1834) and Charles B. Desormes (1777-1862). They placed a pile, composed of no less than 1480 elements, in a boat floating on water: unlike a magnetized box, it assumed no definite orientation. Needless to say, the poles of the pile were not connected, so as not to destroy the electricity!(3)

Of course there were others - mainly chemists, notably Davy and Berzelius - who were using massive piles to drive large currents through closed circuits. They were preoccupied with the whole new world of electricity and chemistry; magnetism was far removed from their immediate concern. In any case theirs was hardly the situation in which to examine the dubious relationship between the two phenomena: their electricity was hardly manifest at all "electrically"; and the lively presence of chemical activity, as well as much heat and light, might well confuse the situation. Indirect, secondary magnetic effects of electricity would be novelty, and these were hardly the direct link which was sought.

In sum, then, in the search for the link between electricity and magnetism - even when the electricity was "galvanic" - the very circumstances that seemed to ensure that the electric agent was present and manifest (a substantial electric tension) were just those likely to make its magnetic influence difficult or impossible! It is as well to recall that both before and for decades after Oersted, there were no established units, standards or meters of electricity or electric current; in a word, no clear "measure" of electricity. Furthermore, the relationship between electricity (charge) and current - although already appreciated in a semi-quantitative way by Volta - was still for most electricians quite vague. Electricity could be strong or weak, currents powerful or feeble, but as to how strong a discharge or how powerful a current might be needed to influence a compass needle - i.e. to produce a magnetic force at some convenient distance comparable with the Earth's - of this there was not the vaguest quantitative idea. What Oersted would discover - at least in part fortuitously - to be necessary was a voltaic cell with plates of a considerable area, immersed in a good solution, connected by such a good conductor that the direct signs of electricity were all but erased, although the secondary ones - heat and chemical decomposition - were quite evident; an apparatus "strong enough to heat a metallic

wire red hot" was Oersted's most precise description of the required current! Only long after - and by virtue of Oersted's discovery did some standard and meaningful measure of electric current become a reality; and only later still could practical, ready-made sources of electric current be taken for granted.

## II.

### Oersted's Experiments

Two aspects of Oersted's discovery should be clearly distinguished: First, the circumstances that permitted the unambiguous detection of the magnetic effects; second the new and wholly surprising configuration of the forces. Oersted did not just discover the magnetic influence of the galvanic current - he also explored its nature. As Faraday remarked of Oersted's brief, but epoch-making announcement:

"It is full of important matter and contains in few words, the results of a great number of observations; and ... comprises a very large part of the facts, that are as yet known relating to this subject." (4)

From the brief review of Oersted's would-be precursors, it is abundantly clear that the discovery of electromagnetism was not simply a matter of investigating the influence of an electric current of "appropriate" magnitude, on a compass needle. There was no measure of "appropriateness" - the current required might have been millions of times more or less! Nor were there ready-made sources of current supply, nor even clear-cut means of measuring currents that were available. What we do know is that the sort of voltaic cells used in some investigations, especially chemical, cells with copper-zinc plate areas of the order 1000 sq. cm. and more, could supply currents - at least for short periods of time, until polarization set in - of several amperes on "short circuit", i.e. through conductors of resistance much smaller than the internal cell resistance (much less, say, than one ohm). (To produce a magnetic field comparable with the horizontal-component of the Earth's, at about 2 or 3 cm. from a wire, a current of few amperes is needed.)

Oersted could hardly have anticipated any more than anyone else, at least in any remotely quantitative sense, the criteria for demonstrating the electrical-magnetic relationship. There were other circumstances which led him to be concerned with voltaic circuits of suitable character. Although Oersted's education was in science and philosophy in the broadest sense, his more practical scientific experience was in the realm of chemistry. He completed a training in pharmacy, and the subject of his Doctoral dissertation was a theory of alkalis. His professional career began, at least in part, as an apothecary, and his early travels (1801) brought him to the wild Ritter at Jena, (5) at a time when the sensation of Volta's pile was at its peak. Whatever was Oersted's

interest in the new electricity, its chemical manifestations must certainly have been prominent in his experience and views. Although a professor of physics - and apparently regarded as much a philosopher as physicist, his electrical investigations have a pronounced chemical character. He discovers that (1803) acid solutions provide stronger Voltaic cells than do salts: stronger here can only refer to current, since, as Volta and his followers stressed, the tension is virtually the same for any solution. In 1812/13 he published his views about chemical laws, in a memoir entitled "Researches on the Identity of Chemical and Electrical Forces". Included in this is a chapter on magnetism, and speculations on its relationship to electricity. His views here are not particularly novel, in fact typical of the time. Thus:

"One has always been tempted to compare magnetic forces with electrical forces. The great resemblance between electrical and magnetic attractions and repulsions and the similarity of their laws necessarily would bring about this comparison."

He quotes the dubious demonstration by Coulomb that, "Magnetism exists in all bodies of nature", (later attributed to magnetic impurities), and adds, to the many analogies between electricity and magnetism, the loss of magnetism in steel by heat "which proves that steel becomes a better conductor through a rise in temperature just as electrical bodies do." (!) He concludes by urging that "an attempt should be made to see if electricity, in its most latent stage, has any action on the magnet as such." (6)

"Latent" here implies galvanic - an activity "halfway between the magnetic force and the electrical force". Whatever else the word connotes, one thing is clear: for Oersted galvanic electricity implies chemical and thermal effects - in short, current, rather than tension. Indeed in the earliest Danish report of his 1821 experiments, written when the results were still somewhat confused (April 1821), Oersted writes

"Since I expected the greatest effect from a discharge [of a pile!] associated with incandescence, I inserted in the circuit a very fine platinum wire above the place where the needle was located." (7)

Currents producing incandescence are a far cry from open-circuited piles of a thousand elements! Whatever the reasoning Oersted's speculations led him to see voltaic electricity as currents,

and as quite strong currents at that. And his practical experience was such that he was able, when demanded, to produce currents of the required strength. A few months after the early report, in July 1820, Oersted published his famous, definitive paper: "Experiments on the Effect of a Current of Electricity on the Magnetic Needle". Current and the closed-circuit are stressed at the outset. The earlier experiments "made with a feeble apparatus were not...sufficiently conclusive", but now they have been repeated and extended "by means of a very powerful galvanic battery". From his brief description we see that Oersted used some 20 cells in series, each with a copper-zinc facing area of some 2000 sq. cm., an arrangement which would have provided currents up to some 10 amps. and a (open-circuited) potential difference, before polarization set in, of about 18 V. For many of his experiments a single cell would have sufficed (the circuit resistance was essentially the internal resistance of the cells); indeed Oersted remarks without further specification that, "A smaller apparatus will answer provided it be strong enough to heat a metallic wire red hot."

If the "metallic wire" were the "very fine platinum wire" referred to earlier, then we might guess that it introduced into the circuit a resistance of the order 1/10 to 1 ohm, with currents of several amperes, then, several cells would be necessary to provide adequate voltage: two or three though not twenty. The principles or practice of assembling cells in series or parallel were more-or-less unknown at the time, and nowhere does Oersted mention such a possibility.

In a later (1830) account of his seminal experiments (8), Oersted refers again to the "luminous and heating effect of the electrical current", which, "goes out in all directions from a conductor", leading him to speculate that "the magnetic effect could likewise eradiate". And the first observation of electromagnetism, Oersted recalls, was made with an apparatus used to demonstrate the heating effect (luminous platinum wire) of the galvanic current.

Fortunately, then, Oersted's philosophical speculations and his practical experience combined to produce just the right opportunity for observing the true electric-magnetic relation; Oersted recognized and exploited it. Having found the magnetic influence of the electric-current by whatever route, Oersted now lets experiment speak, fully and unambiguously, without philosophical prejudices. The essential features of the new interaction are soon delineated.

It is transmitted through materials, as would be expected for a magnetic interaction; it is independent of the material of the conductor wire (Oersted's "uniting conductor"); it is examined for different positions and orientations of the wire, and for the different points around the wire. The remarkable "circularity" of the force (or motion) and its particular "polarity" are established by a law whose "nature will be better seen by a repetition of the experiments than by a long explanation." Only after the experimental verdict is clear, does Oersted permit himself a brief philosophical speculation. Perhaps, he conjectures, positive and negative electricities move in spiral lines, of opposite sense, and correspondingly interact only with north and south magnetic poles, respectively (echoes of DesCartes's magnetic theories?).

Oersted participated but little in the subsequent development of electrodynamics. In 1823 he published<sup>(9)</sup> an account of his work with Joseph Fourier, in which they had shown how to magnify the recently (1822) discovered thermoelectric effect of Thomas Johan Seebeck, by the use of multiple bi-metallic contacts: a sort of "thermoelectric pile" (thermopile). Otherwise the remaining 30 years of his life seem to have been devoted to more philosophical ruminations.

The powerful voltaic battery constructed at the Polytechnic Institute in Paris in 1813 by order of Napoleon who showed exceptional interest in the development of electricity. (Ref II)

(Unless this "artist's impression" is pure imagination, batteries far grander than those used by Oersted were already in existence for years.)

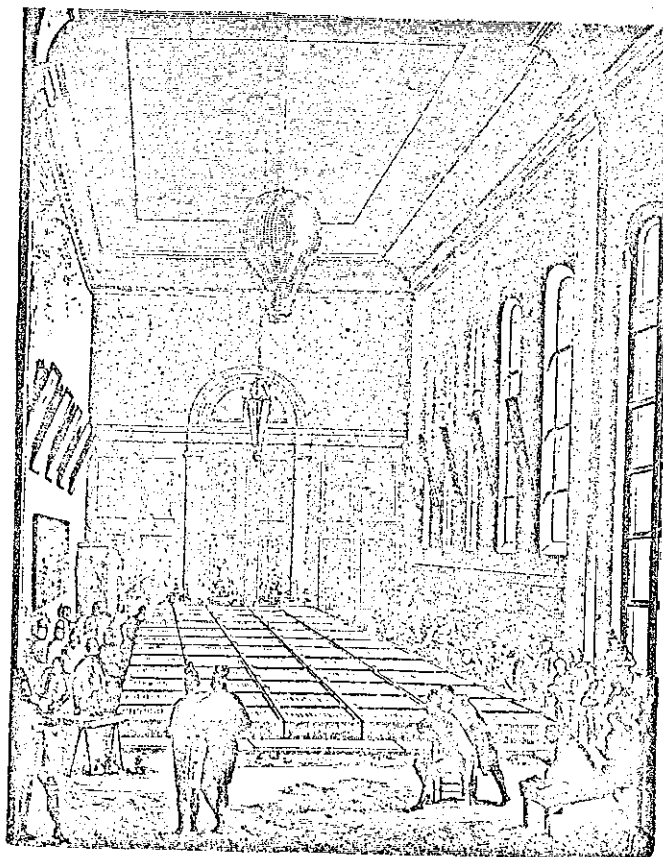

FIGUIER, p. 669

III.

Experiments

Suitable Apparatus (see p.13-15 for details):

Approximately 1 foot of 16 gauge (0.06" diameter) copper wire mounted above a board. Two other wires or metal strips.

Copper wire loop: 1 foot in each direction.

Voltaic cells(copper-zinc) each with an area of 600 sq.cm. or more.

Low voltage ( $1\frac{1}{2}$  v.)  $\frac{1}{2}$  watt electric lamp.

Small, 1"-2" diameter, mounted compass needle of reasonable quality, together with simple (wooden) adjustable supporting stand.

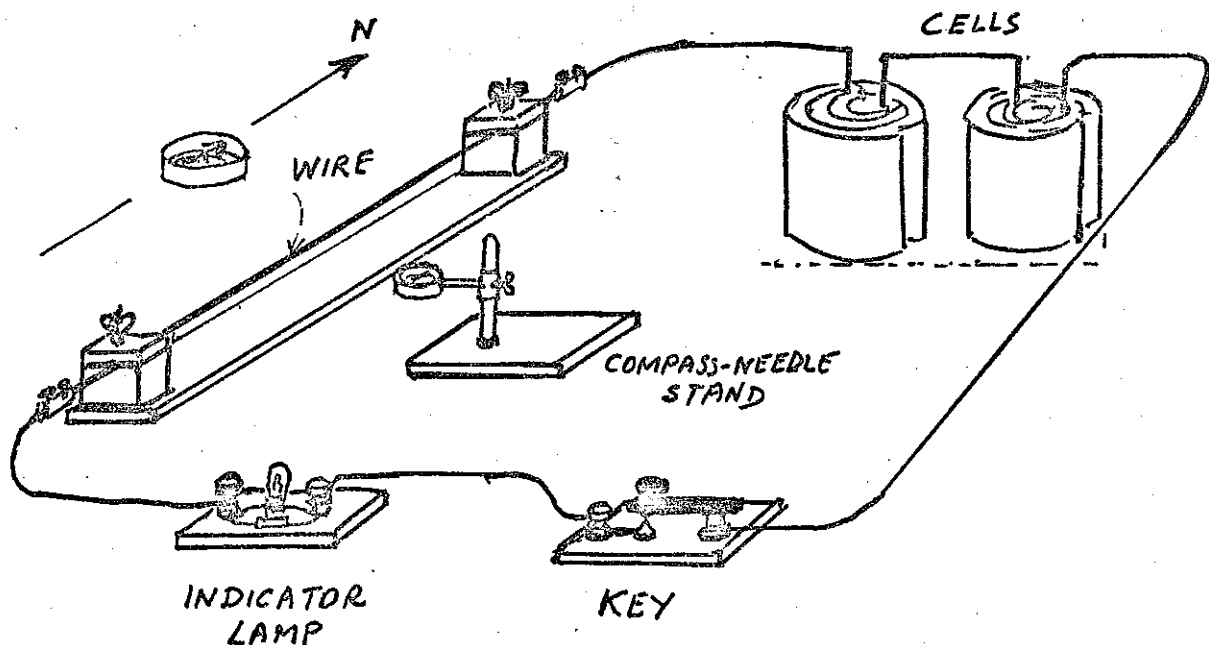

1. Locate and mark out direction of magnetic azimuth. Ensure that there are no magnets or iron bodies in the neighborhood!

2. Place the wire along the direction of the azimuth. Locate:

i) Compass needle (a) above, (b) below, (c) east of, and (d) west of the wire, and as close as possible. In each case observe change in direction of the needle when the circuit is closed momentarily (use tapping-key type switch), but sufficient to observe the glow of the lamp.

ii) Repeat i) (a), (b), (c), (d) with copper-zinc connections to the wire reversed.

iii) Repeat above for several different distances between wire and needle.

3. Move the wire parallel to itself. Observe whether there is any significant change.

4. Turn the wire so that it is at right to the meridian (i.e. points E-W). Repeat 2.i) (a), (b), (c), (d). If a "dipping" motion of the needle is observable, apart from the normal azimuthal motions, record its direction.

5. i) Additional wires in "parallel" with the original one. Observe changes. ii) Use the cells in parallel rather than series. Observe difference.

6. Repeat a significant sample of the observations with different materials (brass, lead, tin, zinc, etc.) in place of the copper wire.

7. With wire in position (2), and needle above wire, examine the effect of interposing various material between wire and needle (copper, wood, lead, etc.).

8. With the closed loop perpendicular and with its plane either parallel or perpendicular to the meridian plane, explore the influence on the compass needle. From observations 1 to 7. You should be able to establish and formulate a rule which describes the influence of the current on the needle, more or less generally. This rule should then be used to explain (or predict!) what is observed in #8.

IV.

Apparatus

1. Voltaic Cells (see p. 15): Oersted used cells of a type, first described by Berzelius, in which the copper electrode is also the container for the liquid electrolyte. Its main feature is the large surface area and small separation of zinc and copper. Somewhat simpler to make, with similar electrical characteristics, and also in common use in Oersted's day, is a cell in which copper and zinc sheets ( $\sim 0.04$  " thick) are interwoven in a spiral fashion. Surface area 1000 sq. cm. A "non-corrosive" electrolyte such as a 1% to 2% solution of common salt may be used; it delivers adequate current (2-4 amps). The arrangement should permit the metal plates to be withdrawn from, and to drain into the electrolyte when the cell is not in use. Two or three such cells which can be connected in series or parallel should be available.

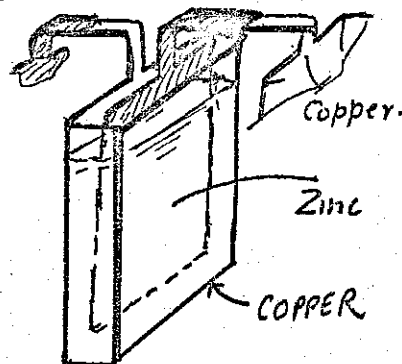

Voltages are small so that contacts and connections must be well made. Tinned surfaces well clamped together (and occasionally cleaned!) are quite satisfactory.

2. Current Indication: In place of Oersted's glowing platinum wire, we can use a small ( $1\frac{1}{2}$ v, 0.4A, e.g. G.E.'s #112) flash-lamp bulb in circuit. When shunted by a 1 ohm resistance, and used together with two Cu-Zn cells in series, it will indicate currents in the range of 1-2 amps. (The internal resistance of the cells is about 0.5 ohm, of the circuit about 0.8 ohm; the E.M.F. about 1.8 volts.)

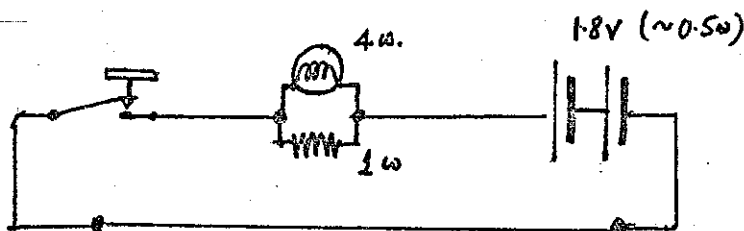

3. Circuit (p.11 ): The resistance of the metallic circuit is small compared with other elements, provided good contacts are made. A pair of clamps holds the straight conductor in place: short copper wires soldered to its ends and themselves tinned are then joined to the connecting wires with brass couplings.

The looped wire can be used either horizontally or vertically.

4. Compass Needle: If the needle works reliably and reproducibly in the Earth's field, it is good enough. The enclosing case should not be much larger than the needle, so that it may be used close to the wire.



FIGUIER, p. 713

Oersted's discovery - an artist's recreation of the scene (How it could not have happened!).

The Oersted medal of The American Association of Physics Teachers pictures a much more plausible experimental arrangement (of course!).

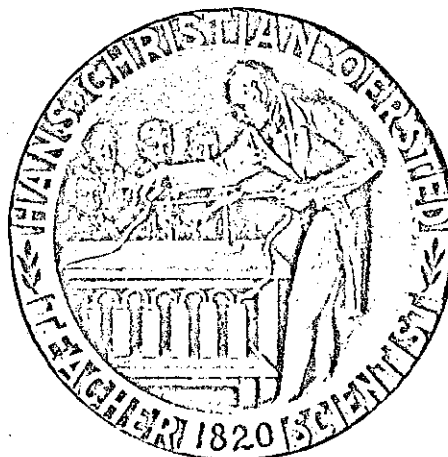

# VOLTAIC CELL (shown in unsubmerged position)

Scale:  $\frac{3}{8}'' = 1''$

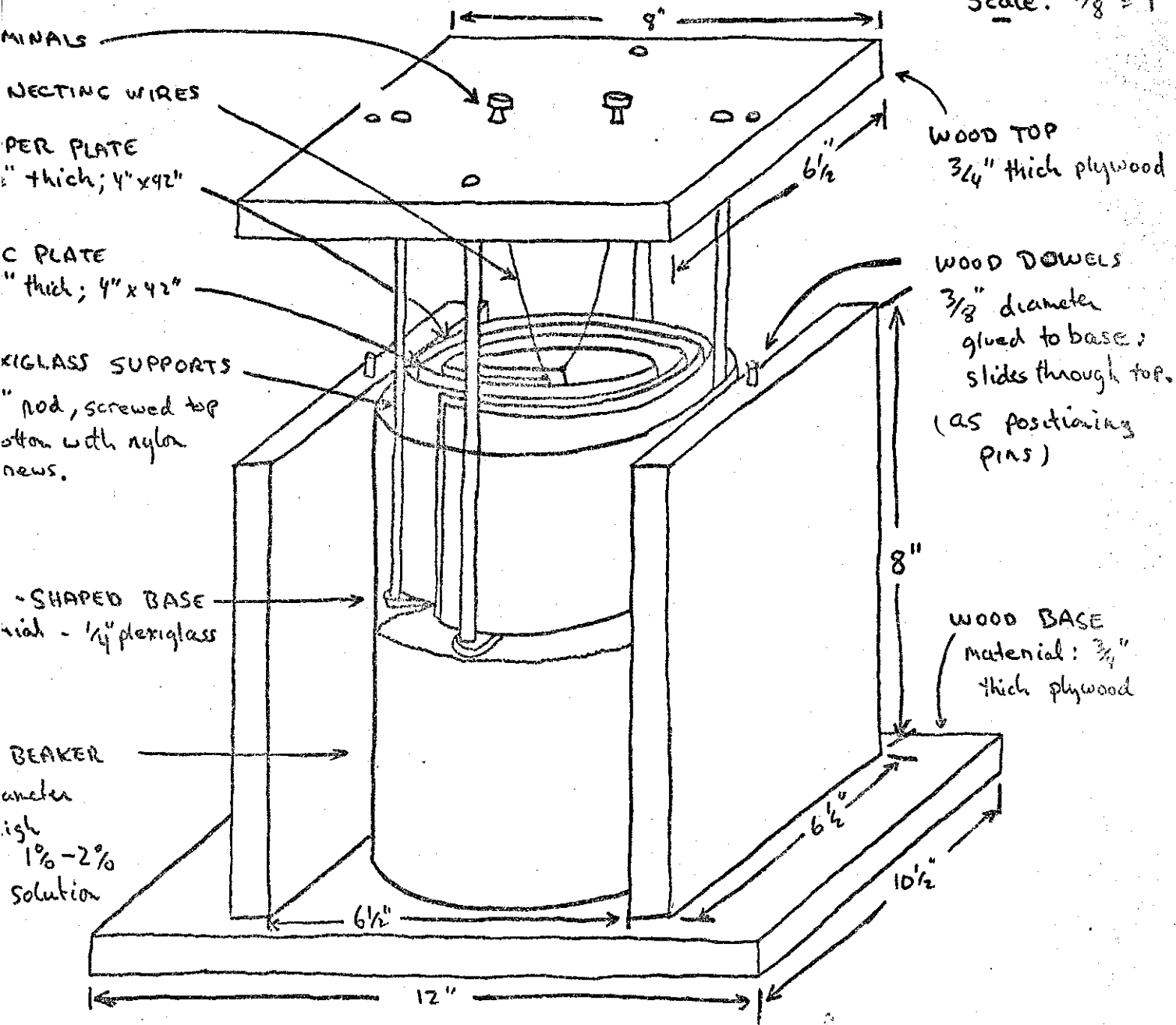

Jul 75  
D.M.

DETAIL DRAWING - cradle for battery plates.

FULL SIZE

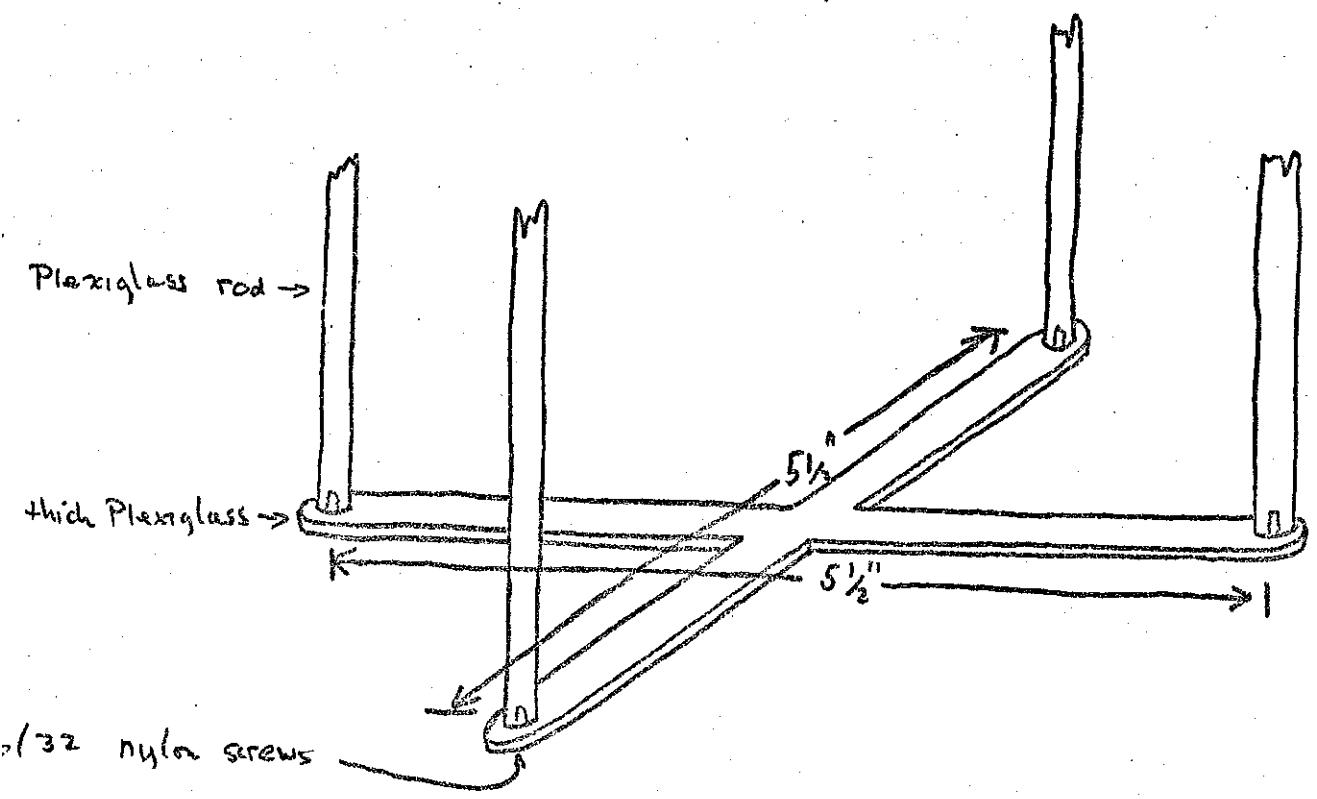

Detail Drawing - Separation of Plates

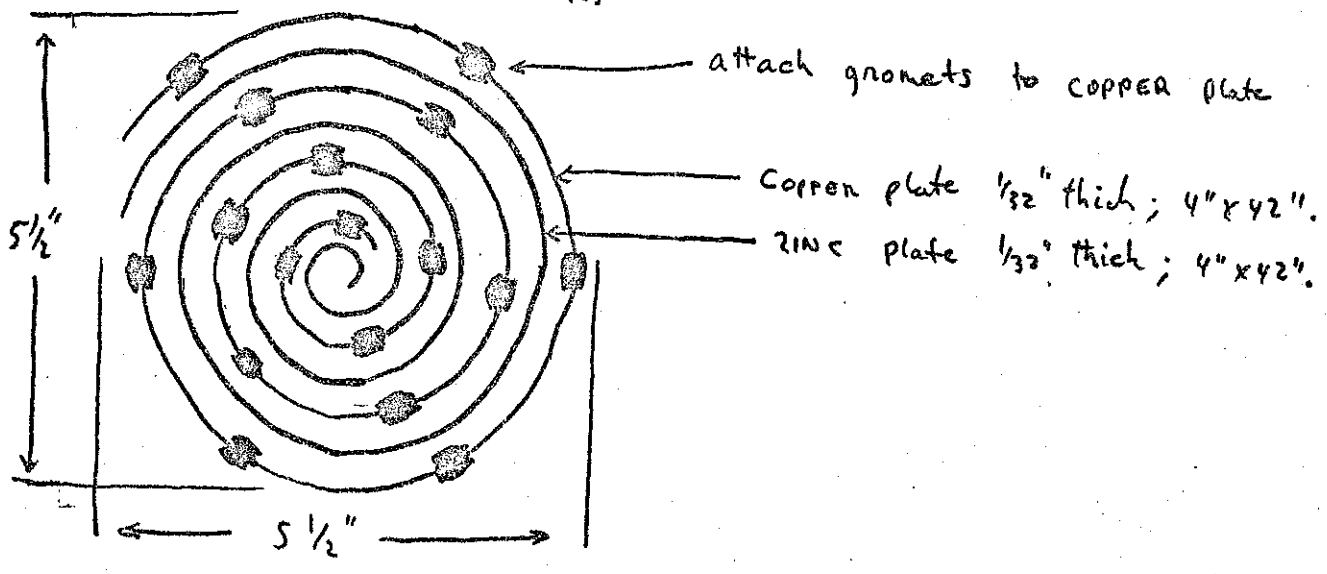

M/S  
DM.

V.

Bibliography

- I. The basic reference is Oersted's paper of July 1820, which was published more-or-less simultaneously, in Latin, French, German, Italian, English and Danish. Oersted's English translation, published in the Annals of Philosophy is appended: p. 19 .
- II. B. Dibner. "Oersted and the Discovery of Electromagnetism". Blaisdell Publishing Company (Paperback), 1962. Essentially the same work was published in 1961 by the Burndy Library, Norwalk, Conn.

Text References:

- 1) Ref. II, p. 49.
- 2) P. F. Mottelay. Biographical History of Electricity and Magnetism. (C. Griffin and Co., London, 1922), p. 383.
- 3) Ibid. pp. 375/376.
- 4) Ref. II, p. 38.
- 5) Ibid. p. 20.
- 6) Ibid. p. 22/23.
- 7) Ibid. p. 29.
- 8) Ibid. p. 31.
- 9) Oersted and Fourier. Annales de Chimie et de la Physique. 22, 375. (1823).

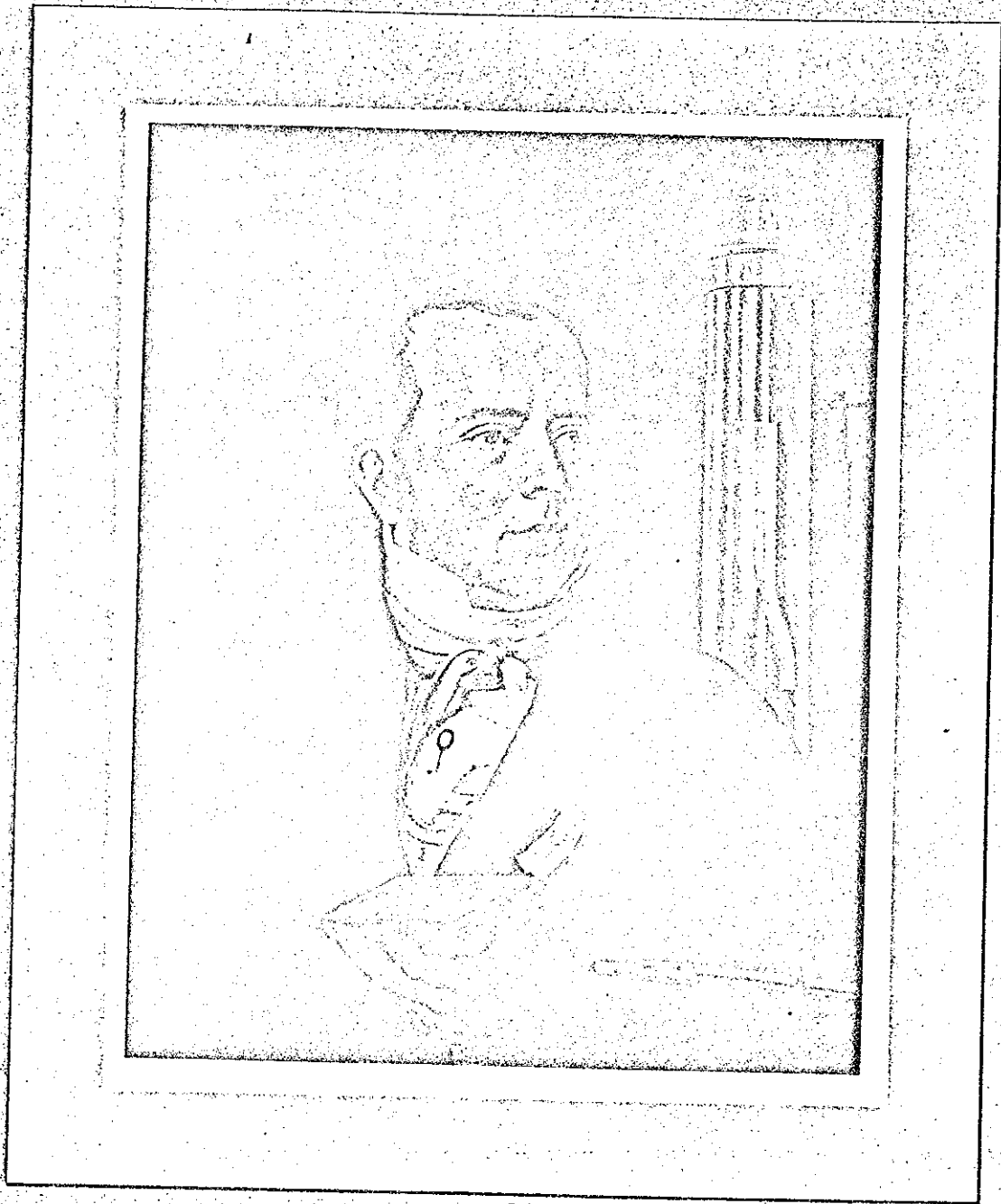

*Painting by D. Hvidt, Copenhagen, after Eckersberg, 1822.*

## HANS CHRISTIAN OERSTED

1777 - 1851

Professor of physics at the University of Copenhagen shown amid the physical apparatus he used in research. On the table is a magnetic needle to denote his discovery of Electromagnetism. The bow was used to create the acoustical figure on the plate in his hand. Behind him is equipment for water compression experiments. He wears the order of Knight of Dannebrog.

# EXPERIMENTA

## CIRCA EFFECTUM

### CONFLICTUS ELECTRICI IN ACUM MAGNETICAM.

---

Prima experimenta circa rem, quam illustrare aggredior, in scholis de Electricitate, Galvanismo et Magnetismo proxime-superiori hieme a me habitis instituta sunt. His experimentis monstrari videbatur, acum magneticam ope apparatus galvanici e situ moveri; idque circulo galvanico cluso, non aperto, ut frustra tentaverunt aliquot abhinc annis physici quidam celeberrimi. Cum autem hæc experimenta apparatu minus efficaci instituta essent, ideoque phænomena edita pro rei gravitate non satis luculenta viderentur, socium adscivi amicum Esmarch, regi a consiliis justitiæ, ut experimenta cum magno apparatu galvanico, a nobis conjunctim instructo, repeterentur et auferentur. Etiam vir egregius Wleugel, eques auratus ord. Dan. et apud nos professor rei gubernatoricæ, experimentis interfuit, nobis socius et testis. Præterea testes fuerunt horum experimentorum vir excellentissimus et a rege summis honoribus decoratus *Hauch*, cujus in rebus naturalibus scientia jam tum inclaruit, vir accuratissimus Reinhardt, Historiæ naturalis Professor, vir in experimentis instituendis sagacissimus Jacobsen, Medicinæ Professor, et Chemicus experientissimus Zeise, Philosophicæ Doctor. Sæpius equidem solus experimenta circa materiam propositam institui, quæ autem ita mihi contigit detegere phænomena, in conventu horum virorum doctissimorum repetivi.

In experimentis recensendis omnia præteribo, quæ ad rationem rei invenientiam quidem conduxerunt, hæc autem inventa rem amplius illustrare nequeunt; in eis igitur, quæ rei rationem perspicue demonstrant, acquiescamus.

Apparatus galvanicus, quo usus sum, constat viginti receptaculis cupreis rectangularibus, quorum et longitudo et altitudo duodecim æqualiter est pollicum, latitudo autem duos pollices et dimidium vix excedit. Quodvis receptaculum duabus laminis cupreis instructum est ita inclinatis, ut baculum cupreum, qui laminam zincæam in aqua receptaculi proximi sustentat, portare possint. Aqua receptaculorum  $\frac{1}{2}$  sui ponderis acidi sulphurici et pariter  $\frac{1}{3}$  acidi nitrici continet. Pars cujusque laminæ Zincæam in aqua submersa Quadratum est, cujus latus circiter longitudinem 16 pollicum habet. Etiam apparatus minores adhiberi possunt, si modo filum metallicum candefacere valeant.

Reproduced in Ref. II.

Professor of Natural History, Mr. Jacobsen, Professor of Medicine, and that very skilful chemist, Mr. Zeise, Doctor of Philosophy. I had often made experiments by myself; but every fact which I had observed was repeated in the presence of these gentlemen.

The galvanic apparatus which we employed consists of 20 copper troughs, the length and height of each of which was 12 inches; but the breadth scarcely exceeded 2 1/4 inches. Every trough is supplied with two plates of copper, so bent that they could carry a copper rod, which supports the zinc plate in the water of the next trough. The water of the troughs contained 1/8th of its weight of sulphuric acid, and an equal quantity of nitric acid. The portion of each zinc plate sunk in the water is a square whose side is about 10 inches in length. A smaller apparatus will answer provided it be strong enough to heat a metallic wire red hot.

The opposite ends of the galvanic battery were joined by a metallic wire, which, for shortness sake, we shall call the *uniting conductor*, or the *uniting wire*. To the effect which takes place in this conductor and in the surrounding space, we shall give the name of the *conflict of electricity*.

Let the straight part of this wire be placed horizontally above the magnetic needle, properly suspended, and parallel to it. If necessary, the uniting wire is bent so as to assume a proper position for the experiment. Things being in this state, the needle will be moved, and the end of it next the negative side of the battery will go westward.

If the distance of the uniting wire does not exceed three-quarters of an inch from the needle, the declination of the needle makes an angle of about 45°. If the distance is increased, the angle diminishes proportionally. The declination likewise varies with the power of the battery.

The uniting wire may change its place, either towards the east or west, provided it continue parallel to the needle, without any other change of the effect than in respect to its quantity. Hence the effect cannot be ascribed to attraction; for the same pole of the magnetic needle, which approaches the uniting wire, while placed on its east side, ought to recede from it when on the west side, if these declinations depended on attractions and repulsions. The uniting conductor may consist of several wires, or metallic ribbons, connected together. The nature of the metal does not alter the effect, but merely the quantity. Wires of platinum, gold, silver, brass, iron, ribbons of lead and tin, a mass of mercury, were employed with equal success. The conductor does not lose its effect, though interrupted by water, unless the interruption amounts to several inches in length.

The effect of the uniting wire passes to the needle through glass, metals, wood, water, resin, stoneware, stones; for it is not taken away by interposing plates of glass, metal or wood.

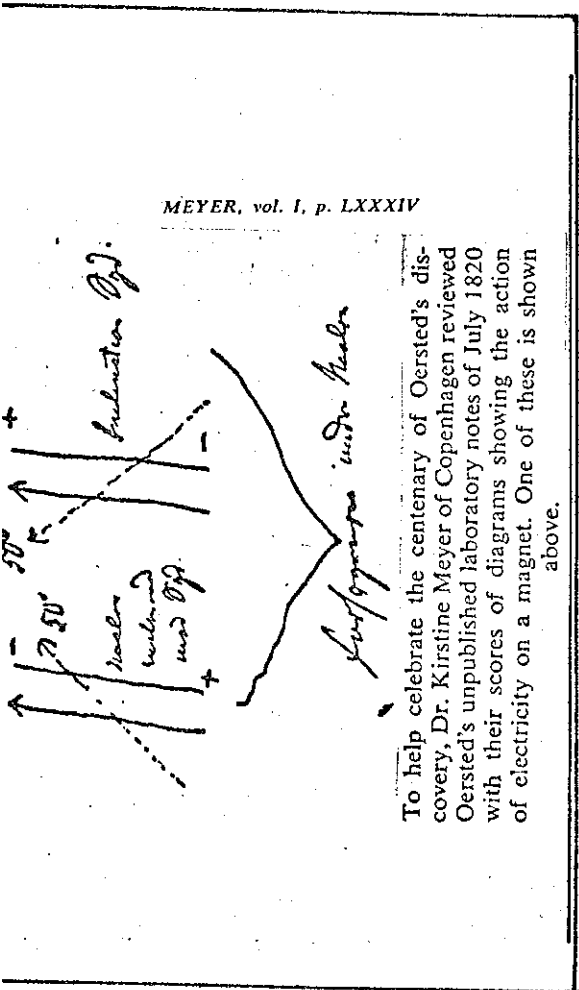

MEYER, vol. I, p. LXXXIV

To help celebrate the centenary of Oersted's discovery, Dr. Kirstine Meyer of Copenhagen reviewed Oersted's unpublished laboratory notes of July 1820 with their scores of diagrams showing the action of electricity on a magnet. One of these is shown above.

English version of Oersted's announcement of July 1820

ANNALS OF PHILOSOPHY. VOL. XVI. P. 273-76. LONDON 1820

*Experiments on the Effect of a Current of Electricity on the Magnetic Needle.\** By John Christian Oersted, Knight of the Order of Danneborg, Professor of Natural Philosophy, and Secretary to the Royal Society of Copenhagen.

THE first experiments respecting the subject which I mean at present to explain, were made by me last winter, while lecturing on electricity, galvanism, and magnetism, in the University. It seemed demonstrated by these experiments that the magnetic needle was moved from its position by the galvanic apparatus, but that the galvanic circle must be complete, and not open, which last method was tried in vain some years ago by very celebrated philosophers. But as these experiments were made with a feeble apparatus, and were not, therefore, sufficiently conclusive, considering the importance of the subject, I associated myself with my friend Esmarck to repeat and extend them by means of a very powerful galvanic battery, provided by us in common. Mr. Wieugel, a Knight of the Order of Danneborg, and at the head of the Pilots, was present at, and assisted in, the experiments. There were present likewise Mr. Hauch, a man very well skilled in the Natural Sciences, Mr. Reinhardt,

\* Translated from a printed account drawn up in Latin by the author, and transmitted by him to the Editor of the *Annals of Philosophy*.

Even glass, metal, and wood, interposed at once, do not destroy, and indeed scarcely diminish the effect. The disc of the electrophorus, plates of porphyry, a stone-ware vessel, even filled with water, were interposed with the same result. We found the effects unchanged when the needle was included in a brass box filled with water. It is needless to observe that the transmission of effects through all these matters has never before been observed in electricity and galvanism. The effects, therefore, which take place in the conflict of electricities are very different from the effects of either of the electricities.

If the uniting wire be placed in a horizontal plane under the magnetic needle, all the effects are the same as when it is above the needle, only they are in an opposite direction; for the pole of the magnetic needle next the negative end of the battery declines to the east.

That these facts may be the more easily retained, we may use this formula—the pole *above* which the *negative* electricity enters is turned to the *west*; *under* which, to the *east*.

If the uniting wire is so turned in a horizontal plane as to form a gradually increasing angle with the magnetic meridian, the declination of the needle *increases*, if the motion of the wire is towards the place of the disturbed needle; but it *diminishes* if the wire moves further from that place.

When the uniting wire is situated in the same horizontal plane in which the needle moves by means of the counterpoise, and parallel to it, no declination is produced either to the east or west; but an *inclination* takes place, so that the pole, next which the negative electricity enters the wire, is *depressed* when the wire is situated on the *west* side, and *elevated* when situated on the *east* side.

If the uniting wire be placed perpendicularly to the plane of the magnetic meridian, whether above or below it, the needle remains at rest, unless it be very near the pole; in that case the pole is *elevated* when the entrance is from the *west* side of the wire, and *depressed*, when from the *east* side.

When the uniting wire is placed perpendicularly opposite to the pole of the magnetic needle, and the upper extremity of the wire receives the negative electricity, the pole is moved towards the east; but when the wire is opposite to a point between the pole and the middle of the needle, the pole is most towards the west. When the upper end of the wire receives positive electricity, the phenomena are reversed.

If the uniting wire is bent so as to form two legs parallel to each other, it repels or attracts the magnetic poles according to the different conditions of the case. Suppose the wire placed opposite to either pole of the needle, so that the plane of the parallel legs is perpendicular to the magnetic meridian, and let the eastern leg be united with the negative end, the western leg with the positive end of the battery: in that case the nearest

pole will be repelled either to the east or west, according to the position of the plane of the legs. The eastmost leg being united with the positive, and the westmost with the negative side of the battery, the nearest pole will be attracted. When the plane of the legs is placed perpendicular to the place between the pole and the middle of the needle, the same effects recur, but reversed.

A brass needle, suspended like a magnetic needle, is not moved by the effect of the uniting wire. Likewise needles of glass and of gum lac remain unacted on.

We may now make a few observations towards explaining these phenomena.

The electric conflict acts only on the magnetic particles of matter. All non-magnetic bodies appear penetrable by the electric conflict, while magnetic bodies, or rather their magnetic particles, resist the passage of this conflict. Hence they can be moved by the impetus of the contending powers.

It is sufficiently evident from the preceding facts that the electric conflict is not confined to the conductor, but dispersed pretty widely in the circumjacent space.

From the preceding facts we may likewise collect that this conflict performs circles; for without this condition, it seems impossible that the one part of the uniting wire, when placed below the magnetic pole, should drive it towards the east, and when placed above it towards the west; for it is the nature of a circle that the motions in opposite parts should have an opposite direction. Besides, a motion in circles, joined with a progressive motion, according to the length of the conductor, ought to form a conchoidal or spiral line; but this, unless I am mistaken, contributes nothing to explain the phenomena hitherto observed.

All the effects on the north pole above-mentioned are easily understood by supposing that negative electricity moves in a spiral line bent towards the right, and propels the north pole, but does not act on the south pole. The effects on the south pole are explained in a similar manner, if we ascribe to positive electricity a contrary motion and power of acting on the south pole, but not upon the north. The agreement of this law with nature will be better seen by a repetition of the experiments than by a long explanation. The mode of judging of the experiments will be much facilitated if the course of the electricities in the uniting wire be pointed out by marks or figures.

I shall merely add to the above that I have demonstrated in a book published five years ago that heat and light consist of the conflict of the electricities. From the observations now stated, we may conclude that a circular motion likewise occurs in these effects. This I think will contribute very much to illustrate the phenomena to which the appellation of polarization of light has been given.