

S. Devans  
Sept 1969

Faraday's Earlier Experiments on the Laws of Electromagnetic  
Induction (1831-1832)

1. The Historical Setting	Pg. 1
2. Faraday	8
3. The Experiments	
(a) Ampère's and de la Rive's and Arago's experiments ✓	12
(b) Faraday's first series of experiments ✓	14
(c) Faraday's second series of experiments	18
4. Faraday's contemporaries	
5. Postscript	
<hr/>	
A. Bibliography	
B. Laboratory Notes	
C. Details of Apparatus	

Faraday's Earlier Experiments in the Laws of Electromagnetic  
Induction (1831-1832)

This Series of Experiments is centered in Faraday's discovery and elucidation of the basic principles involved in what is now termed "electromagnetic-induction."

Sections 1 and 2 provide a brief resumé of the historical setting and Faraday's own place in it.

Section 3a are notes on the more significant attempts to explore the phenomena prior to Faraday's work. Two of these experiments can be performed in the Laboratory.

Sections 3b and 3c are notes on Faraday's experiments in the period 1831-1832. These notes are to be read in conjunction with Faraday's own account: Experimental Researches in Electricity, Vol. I., pp. 1-75. (References are to the numbered paragraphs in this book. )

Details of the experiments in Section 3 which can be reproduced in the Laboratory are contained in the Laboratory folders. (It should be possible to make the experiments first, and then consult Faraday's account, with the notes in 3b, 3c, as required!)

Section 4 contains some brief accounts of the impact of Faraday's discoveries; of contemporaneous discoveries by others; and of investigations which immediately followed them.

Section 5 Some assesment of Faraday's discoveries in the light of later developments.

## The Historical Setting

There is a long history to the speculations concerning the relationship between electricity and magnetism. From the earliest uncertain times of their discovery both were regarded as somewhat magical "occult" 'properties' of particular types of substance -- especially amber, which gave us the name "electricity," and lodestone ( magnetite ore ), which was most commonly associated with magnetism. Both phenomena were associated with mysterious forces, ( at first attraction, but later both attraction and repulsion were observed), which acted without visible contact between bodies, and therefore seemed to differ in some fundamental way from 'real' forces associated with pushing and pulling; i.e., contact. It was natural enough, then, that since electricity and magnetism shared this mysterious feature ("action at a distance"), they should have been suspected as sharing some common origin.

It was through the remarkably systematic -- certainly for their day -- experimental investigations of William Gilbert<sup>1</sup> (1540 - 1603, Physician to Queen Elizabeth 1st) published in his famous work De Magnete (1600), that the essentially different nature of electric and magnetic phenomena (-- or at least those phenomena which were known and studied in his day) was clearly demonstrated. From this period on, for some 200 years, the sciences of electricity and magnetism developed, especially in the eighteenth century, ~~but~~ as totally different sciences.

Many inconclusive, ill-documented, casual observations were reported during this period, of evidence of some connection between electricity and magnetism. Electrical literature contained numerous references to lightning that had magnetised iron and had altered the polarity of compass needles. In the late 1700's, Beccaria and van Marum, among others, had magnetised iron by sending 'electrostatic' charge (i.e., ordinary electricity produced by frictional machines) through it.<sup>2</sup> These claims were no doubt stimulated by the award of prizes, e.g., by the Bavarian Academy in 1774, for the best answer to the question "Is there a real and physical analogy between electric and magnetic forces?" Though answers of both sorts were forthcoming, a positive one would have seemed more likely to succeed than a negative one. In any event, though the problem was a recurrent one, no real progress was made in answering it.

The situation changed dramatically in 1800 with the discovery (invention?) by Alessandro Volta (1745-1827) of the "Voltaic" pile (electro-chemical battery)<sup>3</sup>. This provided a copious and continuous source of electricity in a new form -- the electric 'current'. Within a few years, Voltaic piles of numerous forms and of rapidly increasing size, had been built and with them, numerous new or extended manifestations of electricity had been explored. The older, "ordinary" (frictional) electricity had been a somewhat isolated and exotic branch of science, cultivated as much for its sensational manifestations and entertainment value as for its 'philosophical interest.' But the new, voltaic electricity, as well as exhibiting some of the characteristics of the earlier form, revealed the intimate connections

with heat, light and chemical phenomena. For the ensuing two or three decades, electricity became the foremost experimental branch of natural philosophy; and with the new experimental resources on command, the search for the connection between electricity and magnetism was resumed with more vigor. Success came, if not by accident then at least in singularly fortunate and unlikely circumstances, in 1820, to Hans Christian Oersted (1777-1851), a relatively unknown Professor of Physics at Copenhagen University.<sup>4</sup>

This time the discovery was unambiguous and decisive. Not only was the relationship between voltaic current and magnetism established, but its characteristic form was clearly delineated, and the discovery was reported in a form that made its ready verification by others almost absurdly easy. Within days, Oersted's discovery was verified in the major scientific centers of Europe; and Oersted "woke up one day to find himself a famous man!" Heat, light, chemistry, mechanical forces, and now, magnetism, (not to mention physiological effects and sensations) were all linked together; and electricity seemed to play the central role.

Following rapidly on Oersted's was the discovery by Thomas Johann Seebeck (1770-1831) of a new thermal principle by which electricity could be generated.<sup>5</sup> This provided yet another example of a relationship between two distinct physical phenomena: heat and electricity. But this was also more than just one more example of an interconnection between the variegated manifestations of "Nature's innumerable workings." It was an example of a reciprocal relationship: Electricity produced heat; and, given the appropriate circumstances, heat produced electricity. Likewise, the production of electricity in the voltaic cell and the chemical decomposition by electricity in the electrolytic cell;

or the production of electricity by mechanical force -- in the friction machine, and the forces exhibited by electrified bodies on one another -- had been explored, for example, by Coulomb. The discovery and formulation of the great general principles governing these inter-relations -- the conversion of one form of energy into another as we would say today -- were yet several decades away: but in the early 1800's, and the period from 1820 on especially, the general belief in the existence of such relations was clearly widespread and compelling. To many at that time, there was also the belief that these relationships must be, in some way or another, reciprocal.

The discovery of how 'magnetism' could be generated by electricity provided strong and immediate stimulus to seek the converse: the production of electricity by magnetism. The conviction that such a relation existed was, no doubt, strengthened by the experiments and conjecture of Andre Marie Ampère (1775-1836),<sup>6</sup> who immediately extended and generalised Oersted's findings to include the assertion that all magnetic phenomena were essentially electrical in origin; i.e., not simply that electricity and magnetism were related, but that magnetism was electricity. The precise nature of the 'electric currents' (for ordinary magnetic materials, Ampère pictured them as intramolecular) was of course, then purely a matter of speculation, even if this grand hypothesis were to prove correct. But from this viewpoint there was every reason to expect that electricity in one body -- in the form of magnetism -- should 'induce' electricity in another.

Agustin Fresnel (1788-1827), (a contemporary of Ampère's who is famous chiefly for his contributions to optics) had oversimplified the case by quickly suggesting, in 1820, "that

since a steady (voltaic electric) current produced steady magnetic effects, the converse effect would be detected by merely placing a magnet in the neighborhood of a wire -- and looking for the presence of a steady current. He argued, further, with irrefutable logic (The French 'School' of physics of this period was nothing if not logical), that "this converse effect, though it might be forthcoming, does not necessarily exist." <sup>7</sup>

A few months after Fresnel's suggestion, Ampère himself did set up a very carefully designed, sensitive apparatus to test this conjecture, and the experiment was improved and repeated with a young Swiss collaborator, Auguste de la Rive (1801-1873), on several occasions in the few years following. It is clear in retrospect, as it was all too clear ten years later to Ampère and de la Rive, that the apparatus they had employed was quite adequate to observe the effect they sought: indeed, the effect was in fact produced, but not, unfortunately, correctly or unambiguously recognized. Ampère appears to have been at the time, wholly preoccupied with his belief in the identity of magnetism and electricity, and his approach to experiment was to seek in it a confirmation of his pre-conceived ideas. Insofar as these, and many of Ampère's other experiments, did just this, or appeared to Ampère to do so; and since furthermore his theories had not in any specific way told him how electric currents could be generated by magnets, it is not surprising that Ampère did not notice, still less correctly interpret, an experimental phenomenon he did not anticipate.

These experiments with de la Rive were not the only opportunity by which Ampère was brought face-to-face with the actual phenomenon of "induced" electricity, but failed to perceive its full or precise implications. One of Ampère's

colleagues in Paris was Dominique Francois Jean Arago (1786-1853), a distinguished astronomer and scientist -- mainly in optics. Arago had learnt, from a French instrument maker (H.P. Gambey) that the oscillations of compass-needles were markedly damped when they were placed above a sheet of copper. Arago, in 1824, pursued this matter and observed that continuous rotation of the copper sheet caused the needle to turn in the same direction. At sufficiently high speeds the needle rotated continuously. In London, J.F.W. Herschel and Babbage confirmed this observation, and also demonstrated the reverse: rotation of a magnet could induce rotations in a pivoted copper disc.

Vague speculative notions: such as "magnetism of rotation" were stimulated by these mysterious effects; Arago himself did not subscribe to these extravagances; he restricted his communications to a description of the observations. Two years later (1826) Arago sought the assistance of Ampère (and the use of the more substantial equipment at the College de France) to extend the experiment; to test whether a "solenoid magnet" would behave in the same way as an ordinary magnet. After some mishaps, this demonstration was successful. To Ampère, this success was yet another confirmation of his theory: the equivalence of magnetism and electrical currents. He was not, apparently, prompted to examine why either magnets or solenoids should behave in this mysterious way. (Reference 7, pgs. 193/196)

Quite apart from Ampere's experiments and observations, and the limitations which his whole attitude imposed on them, the idea of electric and magnetic effects in one body inducing corresponding effects in another was a quite familiar prevailing concept. Thus an ordinary electrified body (of the 18th century variety) was well known to be capable of "inducing" electricity in a neighboring unelectrified one. The general circumstances in

which this could be done were well known and understood. Likewise a magnetic body -- a lodestone for example -- could induce magnetism in a neighboring unmagnetised piece of iron. And after Oersted's discovery -- and irrespective of Ampère's theory, experiment demonstrated that (Voltaic) electricity could, inter alia, magnetise a piece of iron. The implications seemed inescapable: Electricity "induces" magnetism; magnetism "induces" electricity; surely, in some way, magnetism must induce electricity. But how?

Logic, as Ampère and colleagues clearly perceived, did not demand that; still less did it suggest how electricity could be produced by magnetism. With much deeper understanding into the relationship between the "molecular currents" than Ampère had, with remarkable insight, conjectured, (and the Voltaic currents which it was sought to induce), an inspired prediction might have been forthcoming. But in retrospect, it was not hard to see how great <sup>was</sup> the gap between Ampère's very general conjecture and the subtle realities of the relationship between magnetism and electric currents; and how unlikely was a leap of the imagination, without some powerful thrust from real experiment, to bridge the great gap between the conjecture of something existing and the nature of its reality.

The stage was clearly set. We know now that the goal was no mirage. The object was properly identified even if not clearly defined. The "theoretical" concepts of the time may have been inadequate for this, but the experimental techniques were more than adequate. The climax, surely, could not long be delayed. When it came, in 1831, there could hardly have been anyone more fitted to play the leading role than Michael Faraday (1791-1867).

Faraday

-2-

One can, without any outright violation of historical actuality, present the history of electromagnetism in terms of the sequence of experimental searches and discoveries, the evolution of concepts and theories, and the ultimate discovery and formulation of general laws, all without any explicit reference to the individual personalities - their characters, accomplishments, or backgrounds. But the history of the laws of electromagnetic induction without Faraday would be hard to conceive. Not only were the contributions which the leading figures -- Ampère and Faraday especially -- so strongly determined by  $\gamma$  and limited by  $\gamma$  the experience and background and style which each brought to their researches; not only was the mode of investigation and the success attained so strongly a reflection of each individuality; but stamped clearly on the actual formulation of the discovered principles and laws is the hallmark of each personality. In the course of time -- often a very long time -- the sharply personal characters become gradually smoothed away: the laws and theories become more abstract and austere, and only faint traces of <sup>their</sup> origin, if any at all, can be discerned in their final "objectivity." But it is, of course, just this lapse of time which permits us to look back and discover now, just how much is 'personality' and how much 'objective reality.' In Faraday's own time, Faraday and Electromagnetism must have been virtually inseparable; even today it takes some effort to separate them.

It would be absurd to attempt any biographical account of Faraday or his work here. He has been widely -- and not simply on the basis of his accomplishments -- acclaimed as "the greatest

experimental philosopher of all time." E. Whittaker concludes the chapter on "Faraday" in his history of Electricity<sup>8</sup> with this tribute:

"Amongst experimental philosophers Faraday holds by universal consent the foremost place. The memoirs in which his discoveries are enshrined will never cease to be read with admiration and delight: and future generations will preserve with an affection not less enduring the personal records and familiar letters which recall the memory of his humble and unselfish spirit."

Before we ~~return~~ return to these memoirs<sup>9</sup>, to see just how Faraday successfully resolved the problem of the production of electricity by magnetism, some bare facts about Faraday must be recalled.

Firstly, Faraday had no formal education or training in science. Until the age of 20, he served as an apprentice to a bookbinder, and gleaned some knowledge of physics and chemistry only by exploiting the opportunities which fortuitously came his way. When he was nearly 22 years old (in 1813) he applied for, and was accepted as, laboratory assistant to Sir Humphrey Davy, (1778-1829), Director of the Royal Institution in London, and a leading 'natural philosopher' of his day (today he would be regarded primarily as a chemist.) Faraday served in this capacity as assistant for several years, but already in 1816 he made his first contribution to science which appeared in his own name. He continued to work as Davy's assistant, but also to experiment and publish small researches of his own -- mostly of a chemical nature. But the problems of electricity and chemistry were, <sup>especially</sup> ~~finally~~ in this period, ineluctably linked together in Davy's studies of galvanism and electro-chemistry. Faraday therefore became thoroughly conversant with the contemporary problems of electricity, and in 1821, he published in the "Annals

of Philosophy" a "History of the Progress of Electromagnetism." In the same year, he demonstrated experimentally, for the first time, how an electric current with a magnet could be made to produce continuous rotations. This was a challenge that, after Oersted's discovery, had engaged the attention of many of the electrical experimenters of the day. In 1823, following up a suggestion of his master - Davy, Faraday liquified chlorine and then extended this work, and showed that many other gases, hitherto considered as permanent, could be liquified by the application of pressure. Between 1823 and 1830 he continued his chemical investigations, which included the discovery of several important new chemical compounds and also became deeply involved in a technical problem: improvement in the manufacture of glass for optical purposes. He also explored, experimentally of course, a problems in mechanical vibrations and sound.

From his apprenticeship and association with Humphrey Davy, and from his own work in the Royal Institution, Faraday had by this time become familiar with a wide range of contemporary science. Years of intensive experimentation had endowed him with great skill and experience. His whole life's work demonstrates how much he was attuned to the scientific spirit of his times: the search for hidden relationships in the infinite variety of natural phenomena; the faith in <sup>the</sup> power of experiment to probe 'Nature' and bring to light its 'Laws.' He not only shared this spirit of the times -- he helped to create it: indeed, he personified it. Though less concerned, perhaps, than his master Davy with the practical fruits of scientific discovery, (he referred to himself as one of the 'philosophers'), he had clearly imbibed Davy's doctrine of the power of experimentation:

"To interrogate Nature with power, not simply as a scholar,

passive and seeking to understand her operations, but rather as a master, active with his own instruments."

In 1829<sup>5</sup>, Davy died and Faraday succeeded him as Director of the Royal Institution. His scientific accomplishments were already considerable and his reputation well-established. He was at an age when many would consider their major work to be completed. But as we now know, Faraday was then just at the beginning of a great scientific career. John Tyndall, who joined Faraday at the Royal Institution in 1851, and later succeeded him, gives this picture of Faraday at the time<sup>10</sup>.

"In 1831 we have him at the climax of his intellectual strength, forty years of age, stored with knowledge, and full of original power. Through reading, lecturing, and experimenting, he had become thoroughly familiar with electrical science: he saw where light was needed and expansion possible. The phenomenon of ordinary electric induction belonged, as it were, to the alphabet of his knowledge: he knew that under ordinary circumstances the presence of an electrified body was sufficient to excite, by induction, an unelectrified body. He knew that the wire which carried an electric current was an electrified body, and still that all attempts had failed to make it excite in other wires a state similar to its own.

What was the reason of this failure? Faraday could never work from the experiments of others, however clearly described. He knew well that from every experiment issued a kind of radiation, luminous in different degrees to different minds, and he hardly trusted himself to reason upon an experiment that he had not seen. In the autumn of 1831 he began to repeat the experiments with electric currents, which, up to that time, had produced no positive result."

### 3. The Experiments

#### 3(a) (i) \*The Ampère - de la Rive Experiment

The simplest notion regarding 'induced' electricity is that a Voltaic current in one conductor will 'induce' a similar current in another conductor close by. Ampère's arrangement was intended as a sensitive test of this possibility. It was conceived very soon after Oersted's discovery, and, as a part of Ampère's series of investigations of 'electrodynamics.' At this time the development of formalised instruments for detecting Voltaic currents had hardly begun. None of the now familiar components of an electrical 'circuit' : sources of e.m.f., connecting wires, switches, solenoids, meters, etc., were, as yet, conceived of as functionally distinct units with formally defined properties. Consequently it is no surprise to find Ampère's designing his apparatus essentially de novo, so as to integrate many of their functions. The Voltaic battery is the only 'standard' piece of equipment.

FIGURE I. The apparatus with which Ampère and De la Rive dimly foresaw the presence of an induced current in 1822. ABCDEF—the loop of the primary circuit; M—a glass tube through which passes a fine thread, suspending the copper ring GHI that forms the secondary circuit; *pk, qn*—supports for an iron horse-shoe magnet (not shown in the diagram) to produce a constant magnetic field inside which the secondary circuit GHI will turn at the moment when the induced current flows.

(Diagram on p. 13.)

The outer heavy conductor **D** takes the current from the battery. The light delicately suspended conductor, **I**, should move under the influence of the (permanent) magnet, **C**,\* if a current flows in it.

- Precautions: (i) If **I** contains some magnetic material this could cause spurious motion.
- (ii) Switching on the large current in **D** might cause mechanical motions

Examine **I** for 'steady' deflections due to 'steady' currents in **a**. To do this, current in **D** must be turned on and off. If transient phenomena are observed, their directions must be described in significant and unambiguous manner.

(Whether or not Ampère and de la Rive observed and correctly recorded a significant positive effect is none too clear. They certainly did not thoroughly explore the phenomena, adequately describe them, or realize their proper - and immense/significance. See S. Ross, Ref.(7), pg.210, et. seq.)

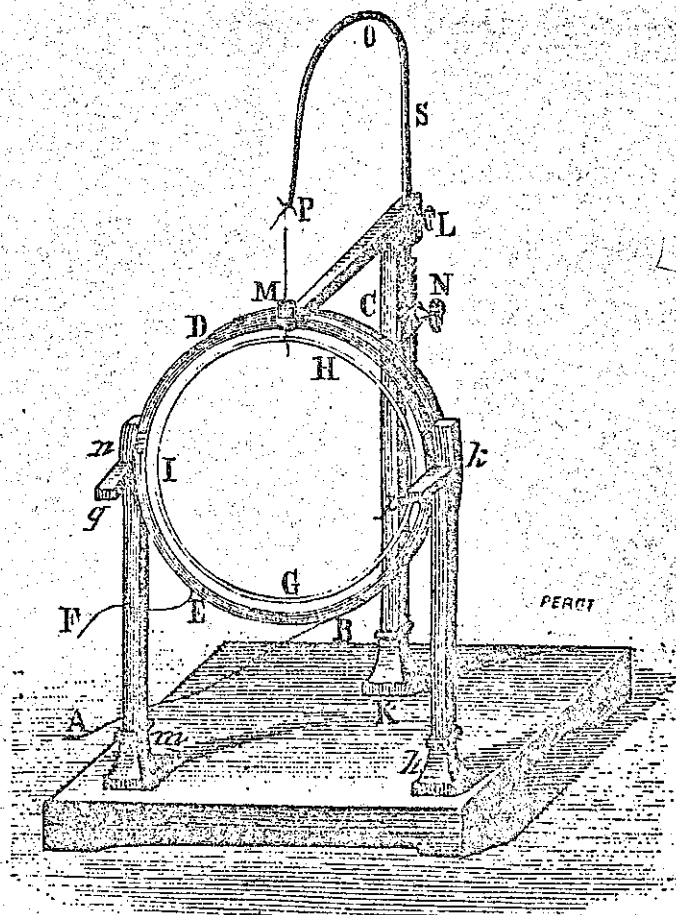

\* Magnet (not shown) rests on brackets *pk, ng*

1859. justification of those who believe in Him. Though the  
Æt. 67-68. fear of death be a great thought, the hope of eternal  
life is a far greater. Much more is the phrase  
the apostle uses in such comparisons. Though sin  
hath reigned unto death, much more is the hope of  
eternal life through Jesus Christ. Though we may  
well fear for ourselves and our faith, much more may  
we trust in Him who is faithful; and though we have  
the treasure in earthen vessels, and so are surrounded  
by the infirmities of the flesh with all the accompany-  
ing hesitation — temptations and the attacks of the  
adversary—yet it is that the excellency of the power  
of God may be with us.

‘What a long, grave wording I have given you; but  
I do not think you will be angry with me. It cannot  
make you sad, the troubles are but for a moment; there  
is a far more exceeding and eternal weight of glory for  
them who, through God’s power, look not at the things  
which are seen, but at the things which are not seen.  
For we are utterly insufficient for these things, but the  
sufficiency is of God, and that makes it fit for His  
people—His strength perfect in their weakness.

‘You see I chat now and then with you as if my  
thoughts were running openly before us on the paper,  
and so it is. My worldly faculties are slipping away  
day by day. Happy is it for all of us that the true good  
lies not in them. As they ebb, may they leave us as  
little children trusting in the Father of mercies and  
accepting His unspeakable gift.

‘I must conclude, for I cannot otherwise get out of  
this strain; but not without love to Constance, and  
kindest remembrances to Mr. Deacon.

‘Ever, your affectionate uncle,

‘M. FARADAY.’

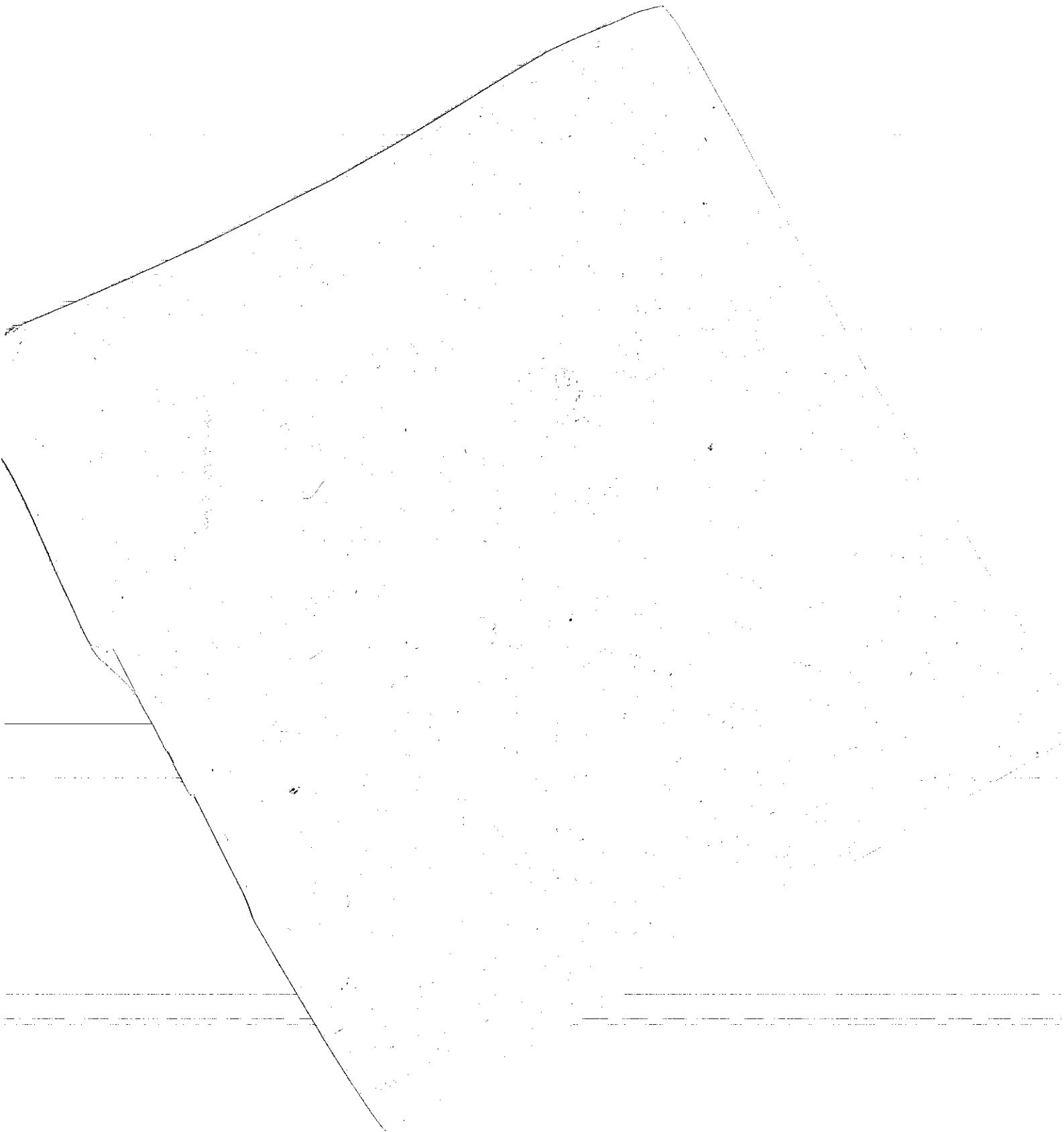

### 3 (a) (ii) Arago's Experiment

The apparatus is simple, self-contained, and its operation straightforward. The copper disc can be rotated at various speeds. It may be replaced by a brass disc. (Brass is, as was well known at the time, a much poorer conductor of electricity than copper.)

One should explore: different locations of the compass needle; effects of different speeds of rotation; of starting and stopping; the significance -- if any, -- of the earth's magnetism (the *local* magnetic meridian should be located); different conductivities *etc.*

How can the significant observations be summarised? Faraday, referring to Arago's earlier work, is skeptical about some of the observations, but commends Arago for restraint and for not beclouding the issues by attempting some ill-formulated or spurious interpretation (See: Faraday, Ref.(9), Vol.I, pp. 81-139, and Ref.(7), pg.194).

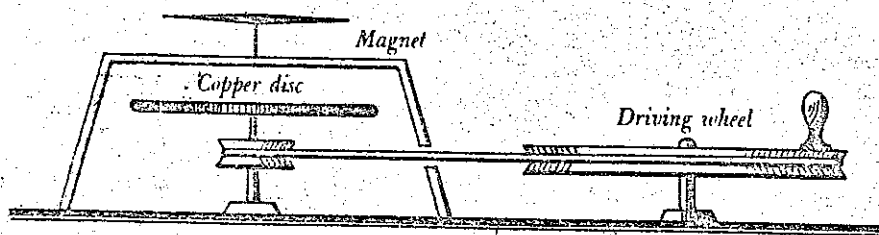

FIGURE 2. The Arago rotation-experiment, disclosed 7 March 1825, by which a magnetic needle is made to drag after a revolving copper disc. (From B. Dibner, *Faraday discloses electro-magnetic induction*, Burndy Library, 1949.)

3 (b) Faraday - First Series, November 1831 (for further practical details, consult laboratory notes)

To be read in conjunction with *Faraday's Experimental Researches in Electricity Vol. I*  
Series I. §§6-139

1. See: Faraday §§<sup>\*</sup> 6-12 (Vol. I)

Notice how the closest proximity of the two coils is attained in accord with the prevalent ideas of 'induced' effects.

2. Faraday §§. 13-17 *an ingenious*

Faraday is here using ~~a~~<sup>an</sup> technique employed earlier by Davy, in an experiment to verify that the ordinary electric discharge - of very short duration - produced magnetic effects similar to those observed by Oersted et. al. with Voltaic electricity. A discharge of short duration may not be sufficient to overcome the inertia of a magnetic needle, but the "magnetic fluid" may be more readily responsive on account of its much smaller inertia. (a perceptive and rather typical conjecture of the time).

In (1) and (2) there are no mechanical motions: only the electricity changes. Now actual motion is ~~induced~~<sup>introduced</sup> as a different means of producing a change in (the magnetic) environment. But Faraday is still investigating the effect of one current on another.

3. Faraday §§. 18-21

That the 'induced' effects are not inhibited, or enhanced, by a prior standing current may seem obvious now, but this experimental verification is typical of Faraday's thoroughness.

§§. 22-26 show a very clear appreciation of the problems of working with 'ordinary' electricity.

§§. 26 Since all the experiments -- so far -- refer to one current acting on another, Faraday chooses a term - "Voltaic-electric induction" which presumes no more than has been observed!

\* §§, refers throughout to paragraph number in *Faraday's Researches*.

4. Faraday §§. 27-35. Returning to the effects of varying currents only, the effect of magnetic materials is demonstrated. Notice also the careful check, as in §§. 18-21.

5. Faraday §§. 36-41. Here the equivalence of "ordinary" — and "electro" - magnets (with or without iron) is demonstrated.

6. Faraday §§. 44-59. Explores different and more powerful means of changing the magnetic state near the conductor in which induced effects are observed.

Notice the final confirmation of Ampère's hypothesis (§§.58). Five or ten years earlier (also §§.3), when the experimental evidence was relatively meagre, Faraday had been cautiously skeptical of Ampère's hypothesis. <sup>And</sup> ~~But~~ he still retains some degree of caution: he distinguishes electric current — induced, and magnetic-induced currents, by different terms (§§.59).

In §§. 60-80, Faraday proposes not so much a theory as a mode of regarding the nature of the induced effects. Because the induced effects are transients, he suggests that they are associated with a change of state of the wire. Turning on the (primary) current induces (in the secondary conductor) a new state: "the electro-tonic state." When the primary current is turned off, the secondary relapses to its former, normal state, and in changing, exhibits the transient current. One can detect here the implicit analogy to ordinary (electrostatic) induction: but Faraday, appealing as always to experiment (§§.63), shows that, as far as he can detect, there is nothing in the way of ordinary electric induction in this case.

Although Faraday later abandons this concept of the "electro-tonic state", the discussion in these sections (§§.60-80) shows

Faraday's remarkable intuition for what is significant. He seemed able - as one of his contemporaries (Weber) put it - "to smell the truth."

7. Faraday §§. 83-96

All the experiments so far have involved "permanent" circuits; whether stationary or not. Now Faraday turns imaginatively to a new type of arrangement involving moveable (sliding) electric contacts. He here demonstrates the same powerfully creative imagination as he had shown earlier (1821) in devising a "continuous" electro-magnetic motion. (The archetype of all electric motors.) He is now about to produce the first continuous electro-magnetic generator of electric current - the archetype of all electric dynamos (c.f. §§.124) He is also -- step-by-step, preparing the way to give a definitive explanation of the mysterious Arago effect.

Notice, §§.87, (in contrast to Ampère five or ten years earlier) a formalised instrument now exists for detecting and measuring (at least in a relative sense) Voltaic (or Galvanic - the two terms were often used interchangeably) currents: a "galvanometer". The form used by Faraday was in common use for several decades. It is based on the magnifying principle of a coil-of-many-turns -- as compared with a single turn: the "multiplier" invented (yes! a coil and helix were invented in the 1820's) by Schweigger.<sup>11</sup> The particular arrangement of pairs of magnetic needles was first proposed by Nobili<sup>12</sup> and is known as a (partially) "astatic" arrangement. Notice again the extraordinary thoroughness with which Faraday explores all types of variation in order to pin down the essential, but no more than the essential, features.

The nature of "magneto-electric" or "galvano-electric" (or, to contain both in a single term: electromagnetic) induction is obviously now clear to Faraday. But the grand momentum of all this experimenting is not easily arrested: still further, interesting checks and demonstrations are made (pp. 100-113).

Finally, pp. 114: The general principle (not a theory) is formulated which not only summarises all the observations made by Faraday himself, but, properly used, is powerful and definite enough to resolve the Arago mystery. (pp. 119-139)

What a remarkable sequence of experiments! Step by step, Faraday proceeds remorselessly -- as if he knows the exact destination. But not a step is missed, and there is hardly a false one: it is as if he is not content to reach his climatic discovery, but to demonstrate that, by following the logic of experiment, arrival at this destination is inevitable. What matter that, as Faraday himself confesses, (pp. 5) the experiments were not ordered precisely "as they were obtained, but in such a manner as to give the most concise view of the whole." However obtained, the inexorable logic of experiment is inescapable. What a difference, for example, to the experiments of Ampère which are, by contrast, almost parenthetical footnotes; Q.E.D.'s to a preconceived theory. And what a contrast to the crude Baconian notion of a mere collection of observations from which generalisations are made inductively. Science is all too frequently divided into its logical (theoretical-mathematical) and empirical (observational-experimental) aspects. Here in Faraday's work is a supreme example of the inseparable combination of experiment and theory, a sequence of observation and deduction which wholly merits Faraday's <sup>own</sup> designation: "experimental philosophy" <sup>of his researches</sup>

### 3 (c) Faraday's Second Series of Experiments

*(To be read in conjunction with Faraday's Experimental Researches in Electricity, §§140-264 Vol. I. Series II.)*

In the first series of experiments Faraday has explored all the essential features of electromagnetic ('Galvano-electric' and 'magneto-electric' in Faraday's terminology) induction and has reached a generalised viewpoint which embraces them all. This is not so much a theory as a sort of viewpoint or mnemonic, suggestive perhaps of some features of theory but still quite vague. Already, even as the experiments are in progress, it is clear that Faraday has doubts about this viewpoint (c.f. footnote to ~~pg.~~ 61).

Scarcely six weeks after the publication of his first account (November 1831), Faraday, in the Bakerian Lecture to the Royal Society (January 1832), presents an account of a whole new series of experiments, and with it a very different -- and much more specific viewpoint. Here one finds the fully developed idea of "magnetic lines of force," an idea which was not wholly new, but one particularly suited to Faraday's graphical but non-mathematical way of thinking. This idea had clearly been in the background in Faraday's thinking for some time: now it was being formalised and developed. This concept was to remain with Faraday and permeates most of his scientific writings. In his own words (§§. 3147 ; 1851):

"The study of these lines have at different times, been greatly influential in leading me to various results, which I think prove their utility as well as their fertility.....I have been so accustomed, indeed, to employ them, and especially in my last researches, that I may, unwittingly, have become prejudiced in their favour, and ceased to be a clear-sighted judge. Still, I have always endeavoured to make experiment the test and controller of theory and opinion; but neither by test

nor by any cross-examination in principle have I been made aware of any error involved in their use."

We shall return later to the question of whether others using this concept were as free of error as Faraday.<sup>13</sup>

3 (b) Faraday (See pp. 140-159)

The previous established laws of induction are verified using the Earth as the magnet. Apart from the intrinsic (and sentimental?) value of this, the earth provides a magnetic field uniform over large regions. Complications due to non-uniformity of the magnetic field can thus be avoided; and under these simpler conditions the new concept of "cutting lines of magnetic force" can be tested most directly. Notwithstanding the clear understanding of the underlying principles, there is genuine fascination with the novelty of the phenomena themselves, as is so plainly and simply evinced in paragraph 154.

3 (c) (2) Faraday pp. 160-170

Here Faraday demonstrates quite dramatically how in some circumstances the induced e.m.f. can result in circulating currents; in others, the same e.m.f. yields simply (unobservable) charge separation but no current.

3 (c) (3) Faraday pp. 171-180

*Electromagnetic Induction*

E.M.F. reduced to its simplest (universal) terms

3 (c) (4) Faraday pp. 180-216

To establish that the induced effect is, in some important respect, independent of the physical nature or composition of the wire cutting lines of force, is of the utmost importance. And this is especially so since in Arago's experiment, a dependence on the material of the disc is observed.

In current language, one would say that the EMF is independent of the material, but that the effects of the EMF -- i.e., the current, is (if Ohm's Law is assumed) the ratio of EMF and Resistance.

But at the time (1831) Ohm's Law was not well known or understood -- nor its relevance here obvious -- partly on account of the obscure and complex manner in which it was propounded. <sup>14</sup>

The simple tests ( pp. 195-197) seem conclusive; but Faraday pursues the matter further, and shows, in essence that the current is dependent on the two factors: the induced effect (EMF) and the conductivity (pp. 208-214). It is easy to invent a minor modification of these -- using the 'null' method of the balanced galvanometer -- to demonstrate the independence of 'EMF' and material. Possibly this is what is implied, not too clearly, in pp.216.

3 (c) (5) Faraday pp. 217

A return to the basic question: "Is "cutting the magnetic

curves" a correct and complete description of the requirement for an induced effect? Is the motion of whatever produces these lines of force itself significant? Is the spatial variation of the lines of force significant?"(c.f. 3b Expt. 1 above)

Faraday §§. 218 Graphite current collectors are used here in place of the mercury contacts. (For 'reasons of health') Faraday would probably have done the same had he had suitable graphite!

3 (c) (6) Faraday §§. 219-230

The experiment in pp. 220-223 can easily be misinterpreted. Does it indicate that the lines of force move with the magnet? PP. 223 provides the clear hint of what is essential!

The experiments in pp. 224-230 further test and confirm this.

Faraday §§. 231-234 show how Faraday conceived *that either* actual motion of a wire in the neighborhood of another current-carrying wire or change in the current in the latter could both be interpreted in terms of cutting lines of magnetic force; and precise relationships between the two cases are established. The emphasis here is on a single principle.

3 (c) (7) Faraday §§. 243-255

Here Faraday seizes on a remarkably novel geometrical feature of the interactions of magnets and currents in wires. It is essentially the discovery of Oersted (Ref.4), that the magnetic lines form concentric circles with the current-carrying wires as axis. But this relationship was so novel -- and so

different from the predominant Newtonian idea of forces along the line joining particles, that Ampère (Ref. 6) insisted on formulating his theory of this magnetic interaction on the basis of the Newtonian principle. Faraday, on the other hand, accepts the direct and convincing evidence of experiment. He recognizes that in actuality, the current-magnet interaction has its own distinctive feature, and he exploits this to demonstrate absolutely convincingly that electro-magnetic induction is sui-generis, and quite distinct from other induced interactions -- e.g., of a magnet and the induced magnetism of a piece of iron.

The particular form of the experiment reproduced in the laboratory is Sturgeon's, pp. 249-255 (which was made several years before Faraday discovered the principles of Electro-magnetic induction). Faraday modifies and extends Sturgeon's experiment with most telling results. (pp. 253). A fitting conclusion to this series of investigations.

Faraday pp. 256-264 The whole series is summarised, although it is by no means asserted that the last word has been spoken! (c.f. pp.256) Indeed, Faraday returns to the whole subject twenty years later (Ref.15) when he explores the question of the 'magnetic lines' inside the magnet itself.

N.B. Throughout the experiment Faraday takes great pains to establish and describe the observed geometrical-directional relationships between such qualities as the direction of the motion: the polarity of the magnet or its "lines of force," and the directions of the currents. To do this some agreed conventions

---

Reference 15, Faraday's Researches Vol. III. Twenty-ninth series. Pgs. 371-401. (1852).

are necessary.

Thus Faraday describes as the "marked pole" of a magnet as that which points to the North (sometimes called a 'north-seeking' pole). (See footnote to pp. 38 and 46). A Voltaic current is taken to be ('positive') in the wire in direction from the copper plate to the zinc plate of the Voltaic battery. ( pp. 38). This is the same convention as in the discharge of ordinary electricity: current from positive (vitreous) to negative (resinous). Clockwise, counter-clockwise and right-handed screwthread have their conventional meaning -- which can, of course, be related to the direction of the earth's rotation (West-East) and N and S polar axes.

## FOOTNOTES

- 1 For a brief sketch of this work and bibliography, see the Notebook for the experiment: "W. Gilbert's Investigations of Magnetism."
- 2 Oersted and the Discovery of Electromagnetism, Bern Dibner, 1962. Especially pgs. 16/17, 24, 42-51.
- 3 For Sketch and bibliography see Notebook for the experiment: "Volta's Discoveries".
- 4 See Notebook for: Magnetic Effects of Voltaic Current  
a) Oersted's Discovery.
- 5 See *W.F. Magie, A Source Book in Physics pp. 461-464*
- 6 See Notebook for Experiments: "Ampère's Demonstrations of the Mathematical Form of the Law of Force Between Current-Carrying Wires."
- 7 "The Search for Electromagnetic Induction" S. Ross, Notes and Records of the Royal Society, Vol. 20, pgs. 184-219. (1965) This paper gives a detailed account of the inconclusive efforts to demonstrate electromagnetic induction -- particularly those of Ampère, that were made in the decade preceding Faraday's work, i.e., 1820-1830.
- 8 Sir Edmund Whittaker: A History of the Theories of Aether and Electricity, 1901 (reprinted Harper 1951). Vol. I Chap. VI.
- 9 Faraday's Experimental Researches in Electricity, 3 Vols, 1839-1855.
- 10 "Faraday as a Discoverer" by John Tyndall (1867) in Royal Institution Library of Science, Vol. 2. pg. 50 (Elsevier 1970).
- 11 J.S.C. Schweigger, (1779-1857) demonstrated this apparatus before the Natural Science Society of Halle, in the same year (1820) as Oersted's discovery.
- 12 Leopoldo Nobili (1784-1835). Professor in Florence. Inventor of the thermoscope (or thermopile); a sensitive electrical method of detecting heat radiation. In connection with this work he invented this sensitive galvanometer arrangement.

## FOOTNOTES (CONT:)

13 Reference 13. M. Faraday, "On Delineation of Lines of Magnetic Force by Iron Filings," "On Lines of Magnetic Force," "On the Physical Character of Lines of Magnetic Force," etc., Faraday's Electrical Researches, Vol.3. pgs. 397-443 (pp. 3234-3299).

14 Reference 14, See Notes on Ohm's Law Experiment.

B. LABORATORY NOTES

for

Faraday's Earlier Experiments

- |    |  |   |
|----|--|---|
| 1) | Earlier work of Arago and Ampere and de-la-Rive. | 2 |
| 2) | Faraday's First Series.                          | 3 |
| 3) | Faraday's Second Series.                         | 7 |

Faraday is acclaimed not only for his numerous outstanding discoveries, but also for his manner of discovery: the supreme art of experimentation. His notebooks and reports are exemplary. To capture the spirit of Faraday's work - and his extraordinary success, one should observe the manner in which he recorded his observations, as well as the way he made them. Therefore:

In all the experiments it is important to record faithfully what is observed at each step. These observations should be recorded -- in proper order -- in a laboratory notebook (NOT on loose scraps of paper) as they are made. Comments and ideas should be interpolated as they occur.

At the completion of any series of experiments, an attempt should be made to summarise the <sup>essence of the</sup> observations, to draw conclusions, and to make a note of further tests necessary to check any hypothesis.

Throughout, a clear distinction ( by maintaining proper ordering in Laboratory book) must be made between

- a) observations (which must stand as a 'permanent' record)
- b) queries, conjectures, ideas, etc. made during observations
- c) Conclusions drawn after the experiments

Experiment 3(a). i. Ampère - de la Rive Experiment (battery required)

The apparatus is a sort of combination of a pair of circuits ( primary and secondary ) for producing 'electromagnetic' induction, and at the same time an instrument for detecting the effect ( if any is produced ).

First the apparatus should be levelled so that the inner loop can turn freely on its suspension thread. A large current from a battery is passed through the outer loop and it can be started and stopped (The lamp is a useful indicator that current is flowing.). Notice carefully any systematic motion of the inner loop, and if convincing effects are observed, describe them all in a single, succinct, clear formulation.

Check (1) Whether the earth's magnetism has any significance.

(2) Whether there is any residual magnetism in the inner loop, which may be responsible for the effect.

Experiment 3(a). ii. Arago's Experiment (No battery)

First establish the magnetic meridian. The apparatus is arranged so that a copper (or brass or iron) metal disc (about 12" diameter) may be rotated at varying speeds. On the platform above it a compass needle may be placed. Also any other magnet may be placed on the upper platform. Observe the effect on the equilibrium position of the compass-needle-rotations. Observe the effect of different speeds, directions

*what?*  
*not clear.*

of rotation, and position (with respect to the axis of rotation) of the compass-needle or magnet.

The magnet and the conducting disc may be interchanged, i.e., the magnet can be clamped down on the rotating (now wooden) disc, and the motion of the freely pivoted copper, brass, or steel plates <sup>abm?</sup> can be examined.

Describe (succinctly) each of your observations as you make them. When all observations are completed, you should try to summarise them by one, or a few, simple principles.

### 3. (b) Faraday's First Series

Experiment 3(b).1. (i) A large current (use special Battery and lamp to indicate the current is flowing) is passed through ~~one~~ the coil: the other is connected to the needle-galvanometer (check position of meridian first).

Carefully observe motion of galvanometer as the first circuit closed; when the current flows; and when the current is discontinued.

Check the effects of these changes on the galvanometer directly (i.e., even if the 'secondary' coil is not connected).

Experiment 3(b).1. (ii) The coils now are made in separate parts. Half are of copper wire, half are of soft iron. All the coils are carefully insulated from each other but they may be connected together in various ways. They are all 'wound' in the same helical sense.

What are the conditions for observing the induced electric

currents? Must coils be (all?) in same helical sense? Is mere proximity enough? How are the effects enhanced?

Experiment 3(b) 2. (Battery required)

You may use the small helix, wound on the glass tube, instead of the galvanometer. Magnetisation may be tested with a small compass-needle. (Note: attraction above does not establish magnetisation. Repulsion does! Why?) What are the necessary relationships of primary and secondary for magnetisation to occur?

Thus: test for magnetisation: (a) by <sup>connecting the</sup> ~~counting~~ coils, switching on current, and then inserting wire. Remove wire first before switching on current. (b) Switch on current after wire is in position: switch off as in (a).

(c) Switch off before removing wire.

Establish the direction (polarity) of magnetisation -- as it relates to the direction of magnetisation which the 'primary' current would produce.

Experiment 3(b) 3. (Battery required)

A simple device to check that relative motion of two circuits is itself significant. (Make sure, of course, that the two circuits are not in electrical contact: insulating paper provided for this.)

What part of the motion is most significant? <sup>In</sup> What direction is the secondary current?

Insert the small battery in the 'secondary' circuit. Establish new galvanometer equilibrium with needle in coil properly. Recheck the 'induced' effects. What conclusion can you draw?

Experiment 3(b) 4. (Battery required)

Magnetic effects are now enhanced by using iron. Closed 'ring' of iron is most favorable for this.

Experiments are similar to those performed in second part of 3(b) 1. In fact, these can be repeated with iron-rod inside coil. Also, iron-rod can be inserted and removed. Compare the magnitude of the effects observed here with those in these earlier experiments.

Distinguish: (a) change of current (in primary ) with iron-'cored' experiments.

(b) Changes due to insertion and removal of iron without changing currents.

As in previous experiment 3(b) 3, check that a small 'standing' current in the secondary does not inhibit 'induced' currents.

Experiment 3(b) 5. (No battery)

Similar to experiment 3(b) 4. Except that now we have No primary current. All the 'secondary' effects are now due to 'ordinary' magnetism.

Establish from your observations a proper systematic way of describing the directions of the secondary effects;

-- one that is consistent with the rules inferred from the earlier observations.

Experiment 3(b) 6. (No Battery)

The powerful "permanent" magnets mounted on the wooden trolley, simulates the large magnet which Faraday loaned and made use of. With it, very large effects can be produced.

Take care in bringing iron, ~~brass~~<sup>brass</sup>, or rods near to the magnet. You can easily hurt your fingers -- not to mention damage the apparatus!

Experiment 3(b) 7. (No Battery)

This is the basic series experiment in which Faraday first: showed how steady currents could be generated by electromagnetic induction, using magnets and motion only (no Voltaic batteries).

second: finally solved the mystery of the Arago Effect.

You should try to establish the essential conditions for observing the steady induced currents:

Where must contacts be placed?

: one on edge, one on axis?

: both on edge?

: What angular positions and separations?

: What is effect of speed?

: Must contacts be near the magnet gap?

What, again, are the essential directions and polarities?

(N.B. A special needle-galvanometer is used here. It is made of, essentially, a single turn of very thick copper. Why?

The connections between it and the disc-apparatus should be as short as practicable. Take account of the effect of the large magnet on the galvanometer. How? What feature of the galvanometer reduces this disturbance?

3c. Faraday's Second Series

3(c) 1 (i) (No Battery)

We are now working <sup>with</sup> the Earth's magnetism. Make sure there are no large pieces of iron or magnets lying nearby. (Modern buildings are not exactly ideal for this type of experiment, but this is the price of Progress.) No battery is needed now! Induced effects similar to 3(b)1 and 3(b)4 can now be observed. Iron is important -- to magnify the effects.

The meridian must be located, and in all observations the position of the apparatus with respect to this meridian noted.

3(c)1(ii)

Similar to 3(b)7. Now the Earth is used in place of the large magnet. Notice that now it is as if the pole face covers the entire disc! Does this make any significant difference?

It is essential now to make observations (e.g., with the disc rotating in a vertical plane) for different orientations with respect to the meridian. It is equally important to summarise your results -- magnitudes, polarities, directions, etc., with respect to the actual North and South poles.

3(c)2 (No Battery)

The currents induced in the rotating copper sphere are explored by the small astatic compass-needle. (The great merit

of the astatic arrangement emerges clearly here.) Once again the axis can be tilted and oriented in various ways. How many essentially different orientations are there? Is there one (?) which yields no current? and one (?) which yields a maximum? Describe (finally) how the currents circulate; find that orientation where the effect is maximal.

3(c)3 (No Battery)

A simple movement of a loop of wire connected to a sensitive galvanometer. What are the essential features: size of loop? thickness of copper wire? Direction of motion, with respect to the meridian? Initial and final positions?

3(c) 4 (No Battery)

How do induced currents depend on the nature of wire material? Wires of Cu, Zn, Fe, and Sn are available. A special needle-galvanometer with two sets of coils is provided. A 'null' (or 'balance') experiment should be devised.

What can be concluded: Material of wire <sup>is</sup> of no significance? - of major importance? - of secondary significance? Can a law of electro-magnetic-induction be formulated for which the material of wire need not be mentioned?

3(c) 5 (No Battery)

Essentially a continuation with new subtleties, of 3(b)7. With the apparatus provided, one can:

- (i) Rotate magnet -- remainder fixed
  - (ii) Rotate disc -- -- -- -- --
- } Both with external --  
(to magnet) circuit.

(iii) Rotate both magnet and disc

Then the return path can be completed through the magnet!  
We can ring-the-changes as above. Carefully record the observed effects in all cases. What is now the essential requirement for induced currents?

3(c) 6

This is essentially similar to 3(c)5 -- now the 'disc' has practically shrunk to vanishing point, but topologically the situation is similar. In this, and previous experiments, Faraday is trying to probe the 'lines-of-force' inside the magnet itself. This problem is further pursued in a later series of experiments.

## IMPORTANT EVENTS IN THE LIFE OF MICHAEL FARADAY

- 1791 Sept. 22 - Born in Newington Butts near London
- 1804 Became errand boy for a bookseller
- 1805 Became bookbinder's apprentice
- 1812 Attended series of 4 lectures given by Humphry Davy
- 1813 Became laboratory assistant to Humphry Davy at the Royal Institution
- 1813-15 Toured Europe with Humphry Davy
- 1816 Published first paper - description of an analysis of a sample of caustic lime
- 1816-20 Published nearly 40 articles and notes in the field of chemistry
- 1820 Discovered two chlorides of carbon
- 1821 Invented method for obtaining continuous rotation by means of voltaic currents (forerunner of electric motor)
- 1821 June 12 - Married Miss Sarah Barnard
- 1823 Liquefied chlorine gas
- 1824 Was elected Fellow of the Royal Society of London
- 1825 Discovered benzene
- 1825 Was appointed Director of the Laboratory at the Royal Institution
- 1825 Started the Friday evening Discourses at the Royal Institution
- 
- 1826 Started the Christmas Lectures for Children
- 1827 Began lecturing at the Royal Institution

- 1831 Discovered electromagnetic induction
- 1832 Demonstrated the identity of frictional and voltaic electricities
- 1832 Formulated the laws of electrolysis
- 1833 Became Fullerian Professor of Chemistry at the Royal Institution
- 1834 Investigated electromagnetic self-induction (discovered independently earlier by Joseph Henry)
- 1836 Studied and clarified various aspects of electrostatic induction
- 1838-44 Engaged in very little research activity due to illness
- 1844 Published his theory of electric and magnetic lines of force
- 1845 Discovered the rotation of the plane of polarization of light in a magnetic field (Faraday effect)
- 1845 Discovered diamagnetism
- 1861 Resigned his professorship at the Royal Institution
- 1862 Terminated his research efforts
- 1862 June 20 - Gave his last lecture at the Royal Institution but was unable to complete it
- 1867 August 25 - Died at Hampton Court near London

FARADAY CONSULTS THE SCHOLARS:  
THE ORIGINS OF THE TERMS OF ELECTROCHEMISTRY

By S. Ross

*Professor of Colloid Science, Rensselaer Polytechnic Institute, Troy, New York*

[Plates 17 and 18]

Hardly any original thoughts on mental or social subjects ever make their way among mankind, or assume their proper importance in the mind even of their inventors, until aptly selected words or phrases have as it were nailed them down and held them fast.

John Stuart Mill, *A system of logic*,  
London, 1843, 2, 285

Our scientists, since they will neoterize, would find their account in entertaining a few consulting philologists.

Fitzedward Hall, *Modern english*,  
New York, 1873, p. 175

THE origins of the terms of electrochemistry—*electrode*, *electrolyte*, *electrolysis*, *anode*, *cathode*, *ion*, *anion* and *cation*—are so fully documented that their story could well become the classic example of how new scientific words are invented and brought into circulation. The story tells of the extraordinary pains taken by a great scientist to secure the precision of his descriptions of facts by defining new words with explicit denotations, as well as of his respect for philological accuracy and euphony. The story is certain to benefit others who meet the same necessity for defining new terms; it has also, of course, a wider utility and interest as a footnote to the history of science.

The words were first published by Michael Faraday, F.R.S. (1791-1867) in 1834, with the barest of acknowledgements to two unnamed friends with whom, he said, 'I have deliberately considered the subject.' No subsequent disclosure of the identity of his friends was ever made public either by Faraday or by the two men themselves. Behind Faraday's apparent lack of courtesy, we can detect his honest reluctance to repay the kindness of his friends by bringing forward their names as though they were partially responsible for judging of the advisability of coining new terms. The identities of Faraday's two friends are now known: they were Whitlock Nicholl, F.R.S. (1786-1838), whose identity is revealed here for the first time; and William Whewell, F.R.S. (1794-1866), a famous Master of Trinity College, Cambridge, whose identity was disclosed in 1868 by John Tyndall, F.R.S. (1).

No full account of Faraday's consultations with these scholars has yet been made: selections from the Faraday-Whewell correspondence (2) have indeed been published from time to time (3, 4, 5, 6) but never in sufficient detail to

disclose all the points discussed between the two men; Dr Nicholl's contributions have been completely overlooked; and the subsequent vicissitudes of the terms have not been traced. The present account brings together a number of previously published letters (many of them from books or journals now hard to find) and others that have not hitherto been published. The author is indebted to the Council of Trinity College, Cambridge, to the Secretary of the Royal Institution and to the Royal Society for permission to publish the new material, which is identified in the Notes. Little information about Whitlock Nicholl has ever been made public, and still less is readily available; more biographical details are therefore included in his case than were deemed necessary for other, better-known figures.

I—*Whitlock Nicholl, F.R.S.*

The friend whom Faraday first consulted about terminology was his personal physician, Dr Whitlock Nicholl. Dr Nicholl had arrived in London in 1826, giving up a country practice in Shropshire for the more stimulating life of the metropolis. This move, sufficiently risky even then, fortunately turned out well, due in great part to Dr Nicholl's qualities of sympathy, sincerity, unselfishness, and gaiety. Testimonies to his personal charm recur frequently in his biography (7). 'The ease with which he could turn from grave to gay . . . his ready wit, his playful humour, and the flow of clever nonsense (8) in which he would sometimes indulge . . . as one of a large merry party in the country, he was a great acquisition . . . dear Whitlock's gaiety of spirits and keen relish for the ludicrous . . . his sallies were always irresistible . . . his kind courtesy of manner, even to the rough and uneducated.'

There was, of course, a great deal more than this to the man: qualities of intellect and of professional competence that would be made evident under other circumstances than a merry party in the country. In 1819 he had published *A Sketch of the Economy of Man*, which he described as 'a physiologico-metaphysico-theologico-anatomico-medico Essay, to combine physiology with metaphysics, and to bring these to strengthen our religious belief'. On purely medical subjects he had published a small text-book, *General Elements of Pathology* (London, 1820), and a number of papers in medical journals. These include: *On Peculiarity of Vision* (9) [colour blindness], *Affections of the Cranial Brain in Infants* and *Erithismal State of the Brain* (10). It is worthy of note that the term *erithism*, used in this last paper, was coined by Dr Nicholl for his purpose.

His interests, as revealed by his publications, evolved gradually from medical to biblical and religious topics, thence to comparative philology.

In 1823 he published *An Analysis of Christianity, exhibiting a connected view of the Scriptures and showing the unity of Subject which pervades the Whole of the Sacred Volume*. At about the same time he undertook the study of Hebrew, in order to be able to read the Scriptures in the original language. He soon extended his study to include an analysis of the construction of the language; and did not hesitate to include the Samaritan, Arabic, Syriac, Chaldee and Persian languages as well, in all of which he detected common roots. These studies led eventually to publications in learned journals of philology, and to his book *Nugae Hebraicae*.

It was no ordinary physician, therefore, to whom Faraday turned for help in the framing of new terms, nor was it to a chance acquaintance. On Nicholl's move to London he first resided in Old Burlington Street, then removed to a house in Curzon Street, Mayfair. At this address he was very near the Royal Institution, in Albemarle Street. Dr Nicholl became a member of the Royal Institution, of the Athenaeum and other clubs. It would not have been long before he became acquainted with Faraday, who had then recently been appointed Director of the Laboratory of the Royal Institution, and who used to invite members to come to evening meetings in the Laboratory—these meetings were the precursors of the famous Friday Evening Discourses. The Athenaeum had been founded in 1824 'for the association of individuals known for their scientific or literary attainments, artists of eminence in any class of the fine arts, and noblemen and gentlemen distinguished as liberal patrons of science, literature, or the arts'. Gentlemen who wanted to join the Club were invited to write to Mr Faraday, Royal Institution, who had undertaken to act as temporary secretary (11).

Dr Nicholl's friendship with Faraday must have been formed readily and flourished rapidly. The connexion was strengthened when, on 18 February 1830, Nicholl was elected a Fellow of the Royal Society, with Faraday's name prominently high among the proposers of his election. His certificate of election was in the following terms (12).

'Whitlock Nicholl, M.D. of 25 Curzon Street, May Fair, a gentleman strongly attached to science and author of several Medical and Physiological papers, being desirous of admission into the Royal Society, we the undersigned do recommend him as a person well worthy of that honour, and likely to become a useful and valuable member thereof.'

The certificate was signed by seventeen Fellows, of whom the first was the celebrated physician B. C. Brodie; Faraday's name came next; other well-known supporters of the recommendation were the brothers Edmund and Frederic Daniell, J. A. Paris, W. T. Brande and W. Heberden. This

distinction confirmed Nicholl's place in the top rank of physicians practising in London.

In a letter (13) written after Nicholl's death, Faraday has given us his estimate of the talents and acquirements of his friend, in terms that carry the stamp of feeling and sincerity. After mentioning some of Nicholl's writings, the letter continues:

I believe there are very few [of his writings] of a philosophical nature. This has often surprised me for his mind was very active amongst such subjects, and frequently when he has come in whilst I have been experimenting the quickness with which he has caught and canvassed the idea under investigation has struck me, and made me wish again and again that he would turn experimenter. So correctly did he catch my thoughts and views that I have often gone to him, as the combined philosopher and scholar, for new words; and several that are now current in electrical science we owe to him.

Again in medical cases, his penetration and judgement often surprised me. I was personally much indebted to him in the matter of health, and so were many of my friends, and when he had occasion to attend us his attention and kindness were never weary. But besides that he appeared to have such a clear perception of the nature of the derangement of the system and to pass so well from the mere symptoms to the true cause of the derangement, and after that to apply the needful remedies so well and so quickly that, though unable to judge of these matters except from experience, I certainly always considered him as a most philosophic and yet a most practical and safe physician.

All here who knew him remember and will continue to remember him; all regret his loss. I never knew a man who so quickly and so generally left pleasant impressions on the minds of those who came into his company—and then that we should be so suddenly struck with the news of his death when we were in a manner waiting for his re-appearance amongst us!

I owe very much to the kindness of those who are or have been around me in life, but in the remembrance of them Dr. Nicholl's character stands very separate and independent, and I think will ever do so. I can wish nothing better to his boy than in all these respects he may prove like his father.

I have the honour to be,  
Dear madam, yours very faithfully  
M. Faraday

The formal  
ment from  
portrait c

My  
B  
that  
your  
short  
P  
and b  
are b  
but I  
you v  
at you  
some  
wine  
not f  
Froder  
yil. w

Altho  
to whom I  
supposed  
29 Novem  
new term  
man, igno  
Two y  
on electro  
how unsat  
which the  
solution of  
poles of a n  
tore apart  
whence re

The bond of friendship between the two men is better revealed in a less formal letter—one that was written to Faraday by Dr Nicholl after his retirement from London, and which Faraday carefully preserved, along with a portrait of Nicholl among his private papers (14).

East Cowes, I.W.

October 31, 1836

My dear friend,

Before I tell you anything of me and mine, I must express my hope that your knee has ceased to trouble you, and that Mrs. Faraday and yourself are well. Your kind call at Shanklin was sadly tantalizing—so short that I could scarcely enjoy the unexpected pleasure of seeing you . . .

Pray let me have a line to tell me how you are—how Mrs. Faraday is, and how all are that you are interested about. I take for granted that you are busily engaged in questioning Nature and in worming out her secrets, but I am pleased in thinking that you do not fatigue yourself so much as you were wont to do. I am quite sure, that, with my friend Mrs. Faraday at your elbow, you will be reminded sufficiently often that the bow must sometimes be released, and that you will be plied with Quinia & port wine when you need these restoratives. My kind regards to Mrs. Faraday, not forgetting the little Margery. Pray offer my kind regards also to Frederic & Edmund Daniell. Believe me to be with real regard and esteem yrs. very faithfully,

Whitlock Nicholl

#### *II—Why Faraday required new terms*

Although never specifically acknowledged, it was probably Dr Nicholl to whom Faraday turned in 1831, when in search of a new term for what he supposed to be an electrically induced condition of metals (15). In a letter of 29 November 1831 to his friend Richard Phillips, Faraday tells (16) of his new term: '*The Electrotonic State*—what do you think of that? Am I not a bold man, ignorant as I am to coin words but I have consulted the scholars.'

Two years later Faraday again felt the need for new terms. His experiments on electrochemical decomposition had progressed far enough to show him how unsatisfactory were the prevailing theories of the subject, according to which the metallic plates at which the voltaic current enters and leaves a solution of a salt or acid were regarded as centres of force analogous to the poles of a magnet; the attractive or repulsive forces emanating from these poles tore apart the molecules of substances lying between them; 'The pole from whence resinous electricity issues attracts hydrogen and repels oxygen, whilst

that from which vitreous electricity proceeds attracts oxygen and repels hydrogen; so that each of the elements of a particle of water, for instance, is subject to an attractive and a repulsive force, acting in contrary directions' (17). Yet, as Faraday pointed out, when the hydrogen or oxygen have been thus elicited at the poles, they are not retained there but are allowed to escape freely; moreover, the hypothesis that the attraction of the poles is the cause of the decomposition leads to the conclusion that the weakest electrical attraction is stronger than the chemical forces that hold together hydrogen and oxygen. The details of the action of the electrical force were necessarily still vague in Faraday's mind, but he rightly sensed that the most urgent requirement at this stage of the development of the subject was to mark as strongly as possible the break that his views made with those of the past.

I conceive the effects to arise from forces which are *internal*, relative to the matter under decomposition—and not *external*, as they might be considered, if directly dependent upon the poles . . . I think, therefore, it would be more philosophical, and more directly expressive of the facts, to speak of such a body, in relation to the current passing through it, rather than to the poles, as they are usually called, in contact with it; and say that whilst under decomposition, oxygen, chlorine, iodine, acids, etc., are rendered at its negative extremity, and combustibles, metals, alkalies, bases, etc., at its positive extremity (18).

One experiment in particular seemed to Faraday of prime importance in proving his thesis; his published text refers back to it more than once, and he described it again, in a letter to Whewell, on an occasion when he was anxious to present his view-point most effectively and succinctly. The following account of it is taken from the *Experimental Researches* (19):

Arrangements were then made in which no metallic communication with the decomposing matter was allowed, but both poles (if they might now be called by that name) formed of air only. A piece of turmeric paper *a* fig. 50, and a piece of litmus paper *b*, were dipped in solution of sulphate of soda, put together so as to form one pointed conductor, and supported on wax between two needle points, one *p* connected by a wire with the conductor of the machine, and the other, *n*, with the discharging train. The interval in each case between the points was about half an inch: the positive point *p* was opposite the litmus paper; the negative point *n* opposite the turmeric. The machine was then worked for a time, upon which evidence of decomposition quickly appeared, for the point of the litmus *b* became reddened from acid evolved there, and the point of the turmeric *a* red from a similar and simultaneous evolution of alkali. . . .

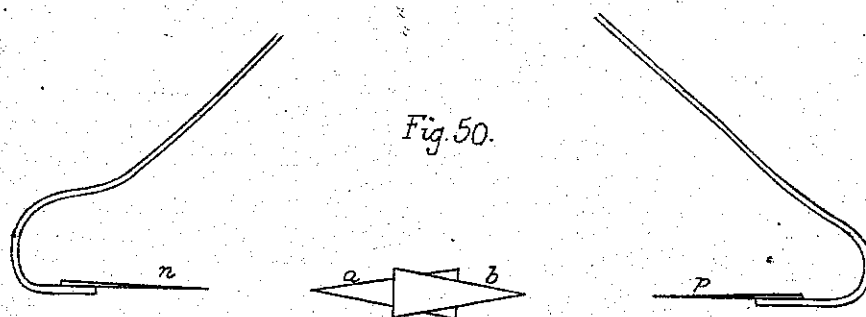

If the combined litmus and turmeric paper in this experiment be considered as constituting a conductor independent of the machine or the discharging train, and the final places of the elements evolved be considered in relation to this conductor, then it will be found that the acid collects at the *negative* or receiving end or pole of the arrangement, and the alkali at the *positive* or delivering extremity. . . .

This case of electro-chemical decomposition is in its nature exactly of the same kind as that affected [*sic*] under ordinary circumstances by the voltaic battery, notwithstanding the great differences as to the presence or absence, or at least as to the nature of the parts usually called poles; and also of the final situation of the elements eliminated at the electrified boundary surfaces. They indicate at once an internal action of the parts suffering decomposition, and appear to show that the power which is effectual in separating the elements is exerted there, and not at the poles.

To make his argument more conclusive Faraday next devised an experiment in which electrochemical decomposition was made to take place against a water surface. His description is too long to quote here: I refer the reader to §§493-496 of the *Experimental Researches*. This experiment, along with the preceding one, formed the basis of Faraday's argument, which he presented as follows (20):

As, therefore, the substances evolved in cases of electro-chemical decomposition may be made to appear against air, which, according to common language, is not a conductor, nor is decomposed, or against water, which is a conductor, and can be decomposed, as well as against the metal poles, which are excellent conductors, but undecomposable, there appears but little reason to consider the phenomena generally, as due to the *attraction* or attractive powers of the latter, when used in the ordinary way, since similar attractions can hardly be imagined in the former instances.

It may be said that the surfaces of air or of water in these cases become the poles, and exert attractive powers; but what proof is there of that, except the fact that the matters evolved collect there, which is the point to be explained, and cannot be justly quoted as its own explanation?

In these extracts we see Faraday trying to frame his new concept of electrochemical decomposition but forced to use the old terminology coined for the earlier concept that he wished to supplant; in particular, the term 'poles', with its undesirable connotations of magnetic or electrostatic attractions and repulsions, caused him embarrassment, as its repeated use seemed to affirm the chief feature of the old theory. We see him trying to manage with such qualifications as 'the parts usually called poles' or 'the electrified boundary surfaces'; but it is evident that he felt the need for a new terminology that would not connote hypothetical interpretations with which he disagreed (20A).

Faraday seems to have consulted Whitlock Nicholl about the substitution of new terms in December 1833. He obtained a number of valuable suggestions: for *poles*, 'which are merely the surfaces or doors by which the electricity enters into or passes out of the substance suffering decomposition', was substituted *electrodes* ( $\eta\lambdaεκτρον$  and  $\delta\delta\acute{o}\varsigma$ , a doorway); bodies that are 'decomposed directly by the electric current, their elements being set free' were to be called *electrolytes* ( $\eta\lambdaεκτρον + λυτ\acute{o}\varsigma$  = that which can be electrically loosened or decomposed); the phrase *electro-chemically decomposed* was to become *electrolyzed*; the *electrolyte* when *electrolyzed* evolves two *electrobeids* (possibly (21) derived from the Greek  $\betaαίνειν$ , to go or  $\betaαδίξειν$ , to walk); the extremities of the solution that are in contact with the *electrodes* and where the *electrobeids* are evolved were to be called the *eisode* (the doorway where the current enters), and the *exode* (the doorway where the current leaves). On 17 December 1833, and later, these terms made their appearance in Faraday's laboratory note-book; on 23 January 1834, he used them publicly in a paper read to the Royal Society; but he was not yet completely satisfied with some of them and still felt the need for a distinction between the *electrobeid* that went to the *eisode* and the one that went to the *exode*. Before the end of April *electrobeid* had been replaced by *zetode* ( $\zeta\etaττειν + \delta\delta\acute{o}\varsigma$  = that which seeks the doorway) and the two zetodes were designated *zeteisode* and *zetexode*. Faraday, however, hesitated about accepting *eisode* and *exode* as they implied rather too strongly that the electric current was an actual current of something flowing—entering and leaving a solution—instead of its being merely an arbitrary convention of language. Faraday's antipathy to the word *current* is expressed several times in his published papers, as for example in the following sentence: 'though I speak of the current as proceeding from the

parts which  
with the c  
scientific  
referring  
current, I r  
two fluids  
still more  
chemistry  
though it

The n  
on this qu  
Fellow of  
tion in 18  
interest in  
distinguish  
(1834), he  
the Middle  
Gothic ar  
aroused a  
problem,  
not yet be  
greatly as  
friends, in  
publicatio  
and entitl  
William V  
his own b  
also its a  
indebtedn  
author of  
*Architectur*

Had V  
to come  
*Principles*  
names *pli*  
nomencla  
Roofs (27

parts which are positive to those which are negative, it is merely in accordance with the conventional, though in some degree tacit, agreement entered into by scientific men, that they may have a constant, certain, and definite means of referring to the direction of the forces of that current' (22). And again: 'By *current*, I mean anything progressive, whether it be a fluid of electricity, or two fluids moving in opposite directions, or merely vibrations, or, speaking still more generally, progressive forces' (23). The new terms of electro-chemistry, unlike the old, must not lend themselves to propagate an analogy as though it were an ascertained fact.

### III—Robert Willis, F.R.S.

The next person of whom we have certain record that he was consulted on this question by Faraday was the Rev. Robert Willis, F.R.S. (1800-1875), Fellow of Caius College, Cambridge, who had lectured at the Royal Institution in 1831 on the subject of sound (24). Willis had not yet indicated his interest in archaeology and architecture, for which he was later to become distinguished; but at the time when Faraday seems to have consulted him (1834), he was actually engaged in writing his *Remarks on the Architecture of the Middle Ages*, destined to be an epoch-making book in the understanding of Gothic architecture (25). Faraday's request would almost certainly have aroused a sympathetic response from Willis, who had frequently met a similar problem, in trying to describe in words certain architectural features that had not yet been given fixed and accepted names. In this dilemma Willis had been greatly assisted by being able to refer to a publication written by one of his friends, in which several of the terms he required had been defined; the publication in question was a slim volume, issued anonymously in 1830 and entitled *Architectural Notes on German Churches*; the author was the Rev. William Whewell, F.R.S., a tutor of Trinity College, Cambridge. In writing his own book Willis was able to consult not only Whewell's publication but also its author, when a question of architectural terminology arose; his indebtedness to Whewell, veiled by the need to respect the anonymity of the author of the *Architectural Notes*, is nevertheless clearly expressed in Willis's *Architecture of the Middle Ages*.

Had Willis needed to persuade Faraday further of Whewell's qualifications to come to his aid he could have pointed to Lyell's recently published *Principles of Geology*, in which Whewell is acknowledged as the source of the names *pliocene*, *miocene* and *eocene* (26); or he could have shown the new nomenclature designed by Whewell for the description of Fan-Tracery Roofs (27); and, as evidence of the conservatism and judgement with which



*London. Published July 26<sup>th</sup> 1835 by Tho. M. Lear, 26 Holborn St.  
Printed by Lejorn Kehler 51 Norman St.*

WILLIAM WHEWELL, F.R.S. (1794-1866)

[Facing page 197

Whewell undertook such tasks, he could have brought forward the following passage from Whewell's *Architectural Notes on German Churches* (28).

In architectural description I have ventured to employ a few new phrases: or rather, I have fixed and limited the meaning of some of the phrases which I have used, with a view to their being employed steadily and precisely for the future. I hope the courteous reader will not consider this to be a criminal assumption of philological power. It is scarcely possible to describe new features without this much of innovation, or to describe anything distinctly without this much of technicality. Mr Rickman has shewn, that by the careful use of terms well selected and previously defined, language may convey almost as exact and complete an idea of a building as can be got from the reality or from the pencil: but in order to do this with the greatest advantage, our architectural vocabulary should be much extended. We may learn from the descriptive sciences, as for instance Botany, how much may be taught by means of a copious and scientific terminology; and architects are already in possession of a very numerous list of terms of art which refer to the Classical Orders; so full, indeed, that there could scarcely ever be much difficulty in describing a building belonging to that style. To establish a complete language for Gothic architecture, is a proceeding which might not be beyond the jurisdiction of our eminent architectural authorities; but such a language would require to be illustrated by abundant drawings and references. I have not pretended to invent or define any words except such as I had occasion for in my own descriptions.

But Faraday did not require this evidence: he was already aware of Whewell's interest in scientific terminology. Early in 1831 Faraday, as editor of the *Journal of the Royal Institution of Great Britain* had accepted and published an article by Whewell *On the employment of notation in Chemistry*. Faraday alludes to this paper in a letter to Whewell dated February 21 1831, in which he says (29):

Your remarks upon chemical notation with the variety of systems which have arisen with regard to notation, nomenclature, rules of proportional or atomic numbers, etc., etc., had almost stirred me up to regret publicly that such hindrances to the progress of science should exist. I cannot help thinking it a most unfortunate thing that men who as experimentalists and philosophers are the most fitted to advance the general course of science and knowledge, should by the promulgation of their own theoretical views under the form of nomenclature, notation

or scale, actually retard its progress. It would not be of much consequence if it was only theory and hypothesis which they thus treated, but they put facts or the current vein of science into the same limited circulation when they describe them in such a way that the initiated only can read them.

Willis then did not do more than draw Faraday's attention to Whewell's interest and ability in scientific nomenclature; but in view of the happy results of his advice he deserves to be included among those who share the credit for forming our present language of electrochemistry.

#### IV—William Whewell, F.R.S.

The Rev. William Whewell (30), to whom Faraday was referred, had been Professor of Mineralogy at Cambridge, from which post he resigned in 1832, due to the sheer number of his other interests. He had recently become widely known as the author of the first of the Bridgewater treatises (31), that on *Astronomy considered with reference to Natural Theology*. But Architecture, Mineralogy, Astronomy and Theology by no means exhausted the number of subjects in which this able and remarkably versatile man took an active interest. At Cambridge and elsewhere his omniscience was soon to become legendary: 'he is a portentous encyclopaedist, and is said to know everything under the sun even better than those who know it best', wrote an enthusiastic visitor (32) in 1858. The direction of Whewell's interests throughout his life showed a notable progression from Mathematics and Mechanics, his first loves, through Chemistry, Mineralogy and Geology; this series of studies culminated with the publication of his *History of the Inductive Sciences* (1837). A new series of studies were inaugurated with the publication of his *Philosophy of the Inductive Sciences* (1840), from which he progressed to Economics, Moral Philosophy and International Law. It may be said that in the course of his intellectual career he gradually and systematically enlarged the objects of his contemplation from the most trivial physical phenomena, which can, however, be described and predicted with mathematical precision, to complex social relations of the utmost human importance.

At about the time of Faraday's request for assistance with terminology, general considerations about the language of science seem to have been occupying Whewell's thoughts. He had already commenced the long task of writing his *Philosophy of the Inductive Sciences*, in which the subject of technical words is discussed at length; he also had recently published a small book on mineralogical classification and nomenclature, as well as some articles in the

*Philological Museum* on definitions and technical terms. His glad and immediate response to Faraday's appeal shows how timely was the enquiry and how appropriate the choice of person to whom it was addressed.

Faraday, on his part, had evidently continued to ponder and probably to discuss with Dr Nicholl his dissatisfaction with the terms he had employed in his oral presentation to the Royal Society in January. It now seemed to him that even to use terms that spoke of electrical current 'entering' and 'leaving' the solution might imply more knowledge of the phenomenon than was warranted; who was to say how false the analogy of 'current' and 'flow' might be to the actual progress of electricity through an electrolyte. Having himself suffered from terms that connoted hypotheses that he considered erroneous, he was anxious to clear the terms of his own invention from any such implications. He decided simply to compare the progress of electricity through a solution with some great terrestrial phenomenon with which it could not possibly be equated. His mind leaped to a suggestion made by Ampère soon after Oersted's celebrated experiment of 1820 had been made public: perhaps terrestrial magnetism results from the presence of an electrical current moving around the equator from east to west, just as north and south magnetic poles can be produced above and below a loop of wire carrying a current that moves in that direction. Let the direction of the current causing electrolysis be compared to this globe-circling current: the two electrodes would then be analogous to east and west. This analogy carries no implications of an electrical fluid entering and leaving the solution, nor does it introduce the puzzle about whether one fluid enters at one electrode and a second fluid enters at the other.

Fortunately for the historian the distance that separated Faraday and Whewell made it necessary for them to carry on their deliberations by correspondence, so that we have a nearly complete record of the stages through which the terms evolved to their final form. Most of the original Faraday-Whewell letters are preserved in the library of Trinity College, Cambridge; some letters are in the Royal Institution. Selections from these letters have been published but many that are important to the present discussion have never appeared in print.

Faraday used little punctuation in his letters, and probably the meticulous punctuation of his published papers was done by another hand. To reproduce his letters in their original form would give a false impression of incoherence; for the purpose of publication, therefore, occasional punctuation has been inserted and obvious mistakes, such as every letter-writer makes, have been quietly corrected. Whewell's letters need little of such editing, as might be expected from his more consciously literary style.

Faraday to Whewell (33)

Royal Institution

24th April, 1834

My dear Sir,

I am in a trouble which when it occurs at Cambridge is, I understand, referred by everybody in the University to you for removal; and I am encouraged by the remembrance of your kindness, and on Mr. Willis' suggestion, to apply to you also. But I should tell you how I stand in the matter.

I wanted some new names to express my facts in Electrical science without involving more theory than I could help, and applied to a friend Dr. Nicholl who has given me some that I intend to adopt: for instance, a body decomposable by the passage of the Electric current I call an 'electrolyte', and instead of saying that water is *electro-chemically decomposed* I say it is *electrolyzed*. The intensity above which a body is decomposed beneath which it conducts without decomposition (34), I call the 'Electrolytic intensity', etc., etc. What have been called the poles of the battery I call the *electrodes*. They are not merely surfaces of metal but even of *water* and *air*, to which the term poles could hardly apply without receiving a new sense. *Electrolytes* must consist of two parts, which during *electrolyzation* are determined the one in one direction the other in the other towards the electrodes or poles where they are evolved. These evolved substances I call *zetodes*, which are therefore the direct constituents of electrolytes.

All these terms I am satisfied with but not with two others which I have used thus far. It is essential to me to have the power of referring to

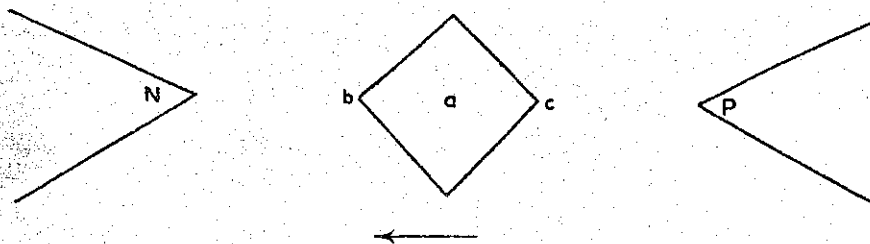

the two surfaces of a decomposable body by which the current enters into and passes out of it, without at the same time referring to the electrodes. Thus let *a* be a decomposable body and *P* and *N* the positive

and negative poles, which may or may not be in contact with *a* at the points *b*, *c*, and shall yet transmit the electricity which passes through *a*. Admitting the usual mode of expression and talking of a current of Electricity proceeding from the positive pole *P* through *a* to the negative pole *N*, my friend suggested and I have used the terms *eisode* for *c* and *exode* for *b*, the points where the *zetodes* are rendered; and a *zetode* going to *c* I have called a *zeteisode* and another going to *b* a *zetexode*.

But the idea of a current especially of *one* current is a very clumsy and hypothetical view of the state of Electrical forces under the circumstances. The idea of *two* currents seems to me still more suspicious, and I have little doubt that the present view of electric currents and the notions by which we try to conceive of them will soon pass away, and I want therefore names by which I can refer to *c* & *b* without involving any theory of the nature of electricity. In searching for a reference on which to found these I can think of nothing but the globe as a magnetic body. If we admit the magnetism of the globe as due to Electric currents running in lines of latitude, their course must be, according to our present modes of expression, from East to West and if a portion of water under decomposition by an electric current be placed so that the current through it shall be parallel to that considered as circulating round the earth, then the oxygen will be rendered towards the east, as at *c* in the figure, and the hydrogen towards the west, as at *b* in the figure. I think therefore that if I were to call *c* the *east-ode* and *b* the *west-ode* I should express these parts by reference to a natural standard which, whatever changes take place in our theories or knowledge of Electricity, will still have the same relation. But *Eastode* or *Westode* or *Oriode* and *Occiode* are names which a scholar could not suffer I understand for a moment, and *anatolode* and *dysiode* have been offered me instead.

Now can you help me out to two good names not depending upon the idea of a current in *one direction only* or upon positive or negative, and to which I may add the prefixes *zet* or *zeto* so as to express the class to which any particular *zetode* may belong.

I am making very free with you but if you feel inclined to help me I shall be very much obliged, and if not make no ceremony in saying that you cannot assist me.

I am, dear Sir,

Your faithful Servt.

M. Faraday

My

of  
int  
to  
for  
vie  
it  
dev  
fut  
the  
lan  
anc  
tionexo  
ano  
just  
the  
anc  
app  
any  
wh  
sec  
me  
not  
wit  
dex  
and  
me  
rigl  
tha  
orth  
em  
Up

Whewell to Faraday (35)

Trinity College, Cambridge  
April 25, 1834

My dear Sir,

I was glad on several accounts to receive your letter. I had the pleasure of being present at the R.S. at the reading of your paper, in which you introduced some of the terms which you mention, and I was rejoiced to hear them, for I saw, or thought I saw, that these novelties had been forced upon you by the novelty of extent and the new relations of your views. In cases where such causes operate, new terms inevitably arise, and it is very fortunate when those upon whom the introduction of these devolves look forwards as carefully as you do to the general bearing and future prospects of the subject; and it is an additional advantage when they humour philologists so far as to avoid gross incongruities of language. I was well satisfied with most of the terms that you mention; and shall be glad and gratified to assist in freeing them from false assumptions and implications, as well as from philological monstrosities.

I have considered the two terms you want to substitute for *eisode* and *exode*, and upon the whole I am disposed to recommend instead of them *anode* and *cathode*; these words may signify eastern and western way, just as well as the longer compounds which you mention, which derive their meaning from words implying rising and setting, notions which *anode* and *cathode* imply more simply. But I will add that as your object appears to me to be to indicate opposition of direction without assuming any hypothesis which may hereafter turn out to be false, *up* and *down*, which must be arbitrary consequences of position on any hypothesis, seem to be free from inconvenience, even in their simplest sense. I may mention too that *anodos* and *cathodos* are good genuine Greek words, and not compounds coined for the purpose. If however you are not satisfied with these, I will propose to you one or two other pairs. For instance, *dexiode* and *sceode* (*skaiode* if you prefer it) may be used to indicate *east* and *west*, agreeably to Greek notions and usages, though their original meaning would be right and left: but I should say in this case also, that right and left, as it cannot be interpreted to imply a false theory, any more than east and west, would be blameless for your object. Another pair, *orthode* and *anthode*, which mean *direct* and *opposite* way might be employed; but I allow that in these you come nearer to an implied theory. Upon the whole I think *anode* and *cathode* much the best.

I have already said that I like most of your new words very well, but there is one which I should be disposed to except from this praise; I mean *zetode*. My objections are these. This word being grouped with others of the same termination might be expected to indicate a modification of *electrode*, as *eisode*, and *exode*, or *anode* and *cathode* do. Instead of this, it means a notion altogether heterogeneous to these, and the *ode* is here the object of a verb *zete*, contrary to the analogy of all the other words. It appears to me that, as what you mean is an element, all that you want is some word which implies an element of a composition, taking a *new* word, however, in order that it may be recollected that the decomposition of which you speak is of a peculiar kind, namely, *electrolytical* decomposition. Perhaps the Greek word *stecheon* (or *stoichion*) would answer the purpose. It has already a place in our scientific language in the term *stoecheiometry*, and has also this analogy in its favour, that whereas your other words in *ode* mean *ways*, this word *stecheon* is derived from a word which signifies to *go in a row*. The elements or *zetodes* are two things which *go*, or *seek to go*, opposite ways. I might add that, if you want a word which has a reference to your other terms, the reference must be to the process of decomposition by which these elements are obtained. You might call your *zetode*, an *electrostecheon*, especially if you had occasion to distinguish these elements obtained by *electrolytical* processes from others obtained by *chemolytical* processes, that is, the common analysis effected by the play of affinities. Elements obtained in the latter way might be called *chemostechions* in opposition to *electrostechion*. But I am afraid I am here venturing beyond my commission and out of my depth; and you must judge whether your *stechions* or *zetodes*, or whatever they are to be, are likely to require the indication of such relations. If you were to take *anode* and *cathode* and adopt *stechion*, I think *anastechion* and *catastechion* might indicate the two *stechions*. If you stick to *zetode*, *anazetode* and *catazetode* would be the proper terms; but perhaps *zetanode* and *zetocathode* would be more analogous to *zetode*, which is a word that, as I have said, I do not much like.

My letter is become so long that I will recapitulate:  
*anode, cathode, zetanode, zetocathode* fulfill your requisitions;  
*anode, cathode, anastechion, catastechion* are what I prefer.

With great interest in your speculations, and best wishes,  
 Believe me, yours very truly, W. Whewell

Faraday to Whewell (36)

R. Institution

3 May, 1834

My dear Sir,

I have waited very impatiently for a proof of my paper that I might send it to you with my letter of thanks for your kindness. But I am afraid I have invoked by that a charge of unthankfulness towards you, which however I assure you I do not deserve.

All your names I and my friend approve of, or nearly all, as to sense and expression; but I am frightened by their length and sound when compounded. As you will see I have taken *dexiode* and *skiaode* because they agree best with my natural standard East and West. I like anode and cathode better as to sound, but all to whom I have shown them have supposed at first that by *anode* I mean *no way*.

Then *Stechion* I have taken although I would rather not have had the hard sound of *ch* here, especially as we have similar sound in both the former words. But when we come to combine it with the two former as *dexio-stechion* and *skatio-stechion*, especially the latter, I am afraid it becomes inadmissible simply from its length and sound forbidding its familiar use; for I think you will agree with me that I had better not give a new word than form one which is not likely to enter into common use.

It is possible that by this time some other shorter word may have occurred for *Stechion*; if so will you favour me with it. If not I think I must strike out the two compounds above and express my meaning without the use of names for the two classes of *stechions*, though they are very very much wanted.

It was the shortness and euphony of *zeteisode* and *zetexode* which were their strong recommendations to me.

I am, my dear Sir,

Your obliged and faithful Servant,

M. Faraday

Can you give me at the bottom of the pages the greek derivations etc., that when you return me the leaves I may have them right for the printer. They are of course uncorrected at present.

M.F.

Whewell to Faraday (37)

Trinity Coll. Cambridge,

May 5, 1834

My dear Sir,

I quite agree with you that *stechion* or *stechion* is an awkward word both from its length and from the letters of which it is composed, and I am very desirous that you should have a better for your purpose. I think I can suggest one, but previous to doing this I would beg you to reconsider the suggestion of *anode* and *cathode* which I offered before. It is very obvious that these words are much simpler than those in your proof sheet, and the advantage of simplicity will be felt very strongly when the words are once firmly established, as by your paper I do not in the least degree doubt that they will be. As to the objection to *anode*, I do not think it is worth hesitating about. *Anodos* and *cathodos* do really mean in Greek *a way up* and *a way down*; and *anodos* does not mean, and cannot mean, according to the analogy of the Greek language, *no way*. It is true that the prefix *an*, put before *adjectives* beginning with a vowel, gives a negative signification, but not to substantives, except through the medium of adjectives. *Anarchos* means *without government*, and hence *anarchia*, *anarchy*, means *the absence of government*: but *anodos* does not and cannot mean *the absence of way*. And if it did mean this as well as *a way up*, it would not cease to mean the latter also; and when introduced in company with *cathodos* nobody who has any tinge of Greek could fail to perceive the meaning at once. The notion of *anodos* meaning *no way* could only suggest itself to persons unfamiliar with Greek, and accidentally acquainted with some English words in which the negative particle is so employed; and those persons who have taken up this notion must have overlooked the very different meaning of negatives applied to substantives and adjectives. Prepositions are so very much the simplest and most decisive way of expressing opposition, or other relations, that it would require some very strong arguments to induce one to adopt any other way of conveying such relations as you want to indicate.

If you take *anode* and *cathode*, I would propose for the two elements resulting from *electrolysis* the terms *anion* and *cation*, which are neuter participles signifying *that which goes up*, and *that which goes down*; and for the two together you might use the term *ions*, instead of *zetodes* or *stechions*. The word is not a substantive in Greek, but it may easily be so taken, and I am persuaded that the brevity and simplicity of the terms you will thus have will in a fortnight procure their universal acceptance. The

*anion* is that which goes to the *anode*, the *cation* is that which goes to the *cathode*. The *th* in the latter word arises from the aspirate in *hodos* (way), and therefore is not to be introduced in cases where the second term has not an aspirate, as *ion* has not.

Your passages would then stand thus:

We purpose calling that towards the east the *anode* and that towards the west the *cathode*. . . . I purpose to distinguish these bodies by calling those *anions* which go to the anode of the decomposing body, and those passing to the cathode, *cations*. And when I have occasion to speak of these together I shall call them *ions*.

ἀνά, upwards, ὁδός, a way; the way which the sun rises.

κατά, downwards, ὁδός, a way; the way which the sun sets.

ἄνιον, that which goes up (neuter participle).

κατίον, that which goes down.

I am so fully persuaded that these terms are from their simplicity preferable to those you have printed, that I shall think it a misfortune to science if you retain the latter. If, however, you still adhere to *dexio* and *scaio*, I am puzzled to combine these with *ion* without so much coalition of vowels as will startle your readers. I put at the bottom of the page the explanation, if you should persist in this.\* I would only beg you to recollect that even violent philological anomalies are soon got over, if they are used to express important laws, as we see in the terms *endosmose* and *exosmose*; and therefore there is little reason for shrinking from objections founded in ignorance against words which are really agreeable to the best analogies. The existing notation of Chemistry owes its wide adoption and long duration to its simplicity.

I am afraid you will think I am fond of playing the critic if I make any further objections, otherwise I would observe on your Article 666, that if you are not sure that you will want such words as *astechion*, it is throwing away your authority to propose them. If what I have written does not answer your purpose, pray let me hear from you again, and believe me,

Yours very truly, W. Whewell.

P.S. If, adopting the term *ion* for *stechion*, you do want the negative *astechion*, I do not think there will be any difficulty in devising a suitable word.

\* δεξιός, on the right hand, and hence the *east*; σκαίός, on the left hand, and hence, the *west*. [This note is Whewell's.]

Before Faraday received this reply to his letter of 3 May he sent an additional note to Whewell, which was received (according to Whewell's notation) on 6 May and promptly answered.

Faraday to Whewell (38)

R. Institution

Monday [5 May, 1834]

My dear Sir,

Hoping that this sheet of paper will reach you before you write to me I hasten to mention two names instead of *eisode* and *exode* which are free I think from objection as to involving a point of theory, namely *Voltode* and *Galvanode*.

My friend Dr. Nicholl proposes *Alphode* and *Betode*.

Then the compounds are good in sound: *Voltastecheon*, *Galvastecheon* or *Alphastechion* and *Betastechion*.

Ever truly yours

M. Faraday

Whewell to Faraday (39)

Trin. Coll. Cambridge

May 6, 1834

My dear Sir,

You will have received my letter of yesterday and perhaps will have formed your opinion of it. I still think *anode* and *cathode* the best terms beyond comparison for the two electrodes. The terms which you mention in your last shew that you are come to the conviction that the essential thing is to express a *difference* and nothing more. This conviction is nearly correct, but I think one may say that it is very desirable in this case to express an *opposition*, a *contrariety*, as well as a *difference*. The terms you suggest are objectionable in not doing this. They are also objectionable it appears to me, in putting forward too ostentatiously the arbitrary nature of the *difference*. To talk of *Alphode* and *Betode* would give some persons the idea that you thought it absurd to pursue the philosophy of the *difference* of the two results, and at any rate would be thought affected by some. *Voltode* and *Galvanode* labour no less under the disadvantage of being not only entirely, but ostentatiously arbitrary, with two additional disadvantages; first that it will

be very difficult for anybody to recollect which is which; and next that I think you are not quite secure that further investigations may not point out some historical incongruity in this reference to Volta and Galvani. I am more and more convinced that *anode* and *cathode* are the right words; and not least, from finding that both you and Dr. Nichols [*sic*] are ready to take any arbitrary opposition or difference. *Ana* and *Kata* which are *prepositions* of the most *familiar* use in composition, which indicate *opposite* relations in *space*, and which yet *cannot* be interpreted as involving a theory appear to me to unite all desirable properties.

I am afraid of urging the claims of *anion* and *cation* though I should certainly take them if it were my business, that which goes to the *anode* and that which goes to the *cathode* appearing to me to be exactly what you want to say. To talk of the two as *ions* would sound a little harsh at first: it would soon be got over. But if you are afraid of this I think that *stechion*, as the accepted Greek name for element, is a very good word to adopt, and then, *anastechion* and *catastechion* are the two contrary elements, which I am sure are much better words than you can get at by using *dexio* and *scaio* or any other terms not prepositions.

I expect to be in London Friday and Saturday, and if I am shall try to see you on one of those days and to learn what you finally select.

Believe me

Yours most truly

W. Whewell

Faraday to Whewell (40)

Royal Institution

15 May 1834

My dear Sir,

I ought before this to have thanked you for your great kindness in the matter of the names respecting which I applied to you; but I hoped to have met you last Saturday at Kensington (41) and therefore delayed expressing my obligations.

I have taken your advice and the names used are *anode cathode anions cations* and *ions*—the last I shall have but little occasion for. I had some hot objections made to them here and found myself very much in the condition of the man with his Son and Ass who tried to please everybody; but when I held up the shield of your authority it was wonderful to observe how the tone of objection melted away.

I am quite delighted with the facility of expression which the new terms give me and shall ever be your debtor for the kind assistance you have given me.

I am, My dear Sir,  
Your obligd. and faithful Servant,  
M. Faraday

Faraday to Whewell (42)

Royal Institution

17 June 1834

Dear Sir,

I beg to offer you a copy of the 6th and 7th series etc. and am anxious again to thank you for your kindness in the matter of the names. I felt during the printing very well pleased with the way in which they read.

I take the liberty of putting 3 or 4 other copies into the parcel but have some suspicion that I am using too much liberty with you. I hope however you will excuse me and I will endeavour to find out some other means of transfer hereafter. I am

Dear Sir  
Your Very Obliged Servant  
M. Faraday

In the section of his book *The Philosophy of the Inductive Sciences* that is devoted to the language of science, Whewell amplified his objection to the suggestions made by Faraday and Dr Nicholl, though without revealing that he had played any part himself in the events he discussed. The book was published in 1840. Whewell wrote (43):

The extension of arbitrary names in scientific terminology is by no means to be encouraged. I may mention a case in which it was very properly avoided. When Mr. Faraday's researches on Voltaic electricity had led him to perceive the great impropriety of the term *poles*, as applied to the apparatus, since the processes have not reference to any opposed points, but to two opposite directions of a path, he very suitably wished to substitute for the phrases *positive pole* and *negative pole* two words ending in *ode*, from *ὁδός*, a way. A person who did not see the value of our present maxim, that descriptive terms should be descriptive in their origin, might have proposed words perfectly arbitrary, as *Alphode* and *Betode*: or, if he wished to pay a tribute of respect to the discoverers in

this department of science, *Galvanode* and *Voltaode*. But such words would very justly have been rejected by Mr. Faraday, and would hardly have obtained any general currency among men of science. *Zincode* and *Platinode*, terms derived from the metal which, in one modification of the apparatus, forms what was previously termed the pole, are to be avoided, because in their origin too much is casual; and they are not a good basis for derivative terms. The pole at which the zinc is, is the Anode or Cathode, according as it is associated with different metals. Either the *zincode* must sometimes mean the pole at which the Zinc is, and at other times that at which the Zinc is not, or else we must have as many names for poles as there are metals. *Anode* and *Cathode*, the terms which Mr. Faraday adopted, were free from these objections; for they refer to a natural standard of the direction of the voltaic current, in a manner which, though perhaps not obvious at first sight, is easily understood and retained. *Anode* and *Cathode*, the *rising* and the *setting* way, are the directions which correspond to east and west in that voltaic current to which we must ascribe terrestrial magnetism. And with these words it was easy to connect *anion* and *cathion*, to designate the opposite elements which are separated and liberated at the two *electrodes*.

#### V—Publication and reception of the new terms

Faraday was convinced after receiving Whewell's letter of 6 May 1834. He changed the proof-sheets of his *Experimental Researches*, 7th Series, substituting Whewell's suggestions. The paper begins by introducing the new terms, as follows (44):

The theory which I believe to be a true expression of the facts of electro-chemical decomposition . . . is so much at variance with those previously advanced, that I find the greatest difficulty in stating results, as I think, correctly, whilst limited to the use of terms which are current with a certain accepted meaning. . .

To avoid, therefore, confusion and circumlocution, and for the sake of greater precision of expression than I can otherwise obtain, I have deliberately considered the subject with two friends, and with their assistance and concurrence in framing them, I purpose henceforward using certain other terms, which I will now define. The *poles*, as they are usually called, are only the doors or ways by which the electric current passes into and out of the decomposing body; and they of course, when in

contact with that body, are the limits of its extent in the direction of the current. The term has been generally applied to the metal surfaces in contact with the decomposing substance; but whether philosophers generally would also apply it to the surfaces of air and water, against which I have effected electro-chemical decomposition, is subject to doubt. In place of the term pole, I propose using that of *Electrode*, and I mean thereby that substance, or rather surface, whether of air, water, metal, or any other body, which bounds the extent of the decomposing matter in the direction of the electric current.

The surfaces at which, according to common phraseology, the electric current enters and leaves a decomposing body, are most important places of action, and require to be distinguished apart from the poles, with which they are mostly, and the electrodes, with which they are always, in contact. Wishing for a natural standard of electric direction to which I might refer these, expressive of their difference and at the same time free from all theory, I have thought it might be found in the earth. If the magnetism of the earth be due to electric currents passing round it, the latter must be in a constant direction, which, according to present usage of speech, would be from east to west, or, which will strengthen this help to the memory, that in which the sun appears to move. If in any case of electro-decomposition we consider the decomposing body as placed so that the current passing through it shall be in the same direction, and parallel to that supposed to exist in the earth, then the surfaces at which the electricity is passing into and out of the substance would have an invariable reference, and exhibit constantly the same relations of powers. Upon this notion we purpose calling that towards the east the *anode*, and that towards the west the *cathode*; and whatever changes may take place in our views of the nature of electricity and electrical action, as they must affect the *natural standard* referred to, in the same direction, and to an equal amount with any decomposing substances to which these terms may at any time be applied, there seems no reason to expect that they will lead to confusion, or tend in any way to support false views. The *anode* is therefore that surface at which the electric current according to our present expression, enters: it is the *negative* extremity of the decomposing body; is where oxygen, chlorine, acids, etc., are evolved; and is against or opposite the positive electrode. The *cathode* is that surface at which the current leaves the decomposing body, and is its *positive* extremity; the combustible bodies, metals, alkalies and bases, are evolved there, and it is in contact with the negative electrode.

ion of the  
 surfaces in  
 philosophers  
 r, against  
 to doubt.  
 d I mean  
 metal, or  
 matter in  
 e electric  
 mportant  
 he poles,  
 they are  
 ection to  
 the same  
 he earth.  
 round it,  
 o present  
 rengthen  
 If in my  
 bod, as  
 irection,  
 urfaces at  
 ould have  
 ations of  
 e east the  
 ges may  
 action, as  
 irection,  
 ich these  
 pect that  
 e views.  
 ccording  
 y of the  
 evolved;  
 at surface  
 s positive  
 evolved

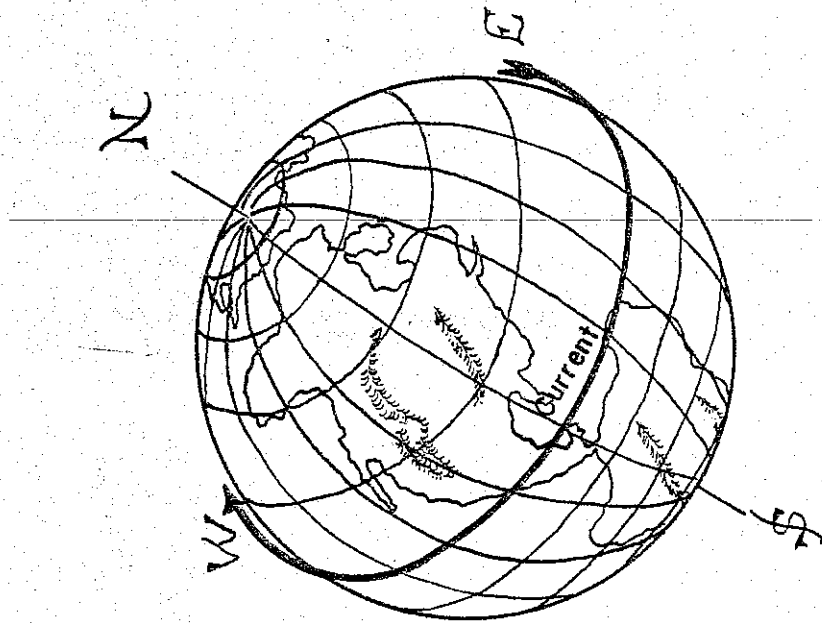
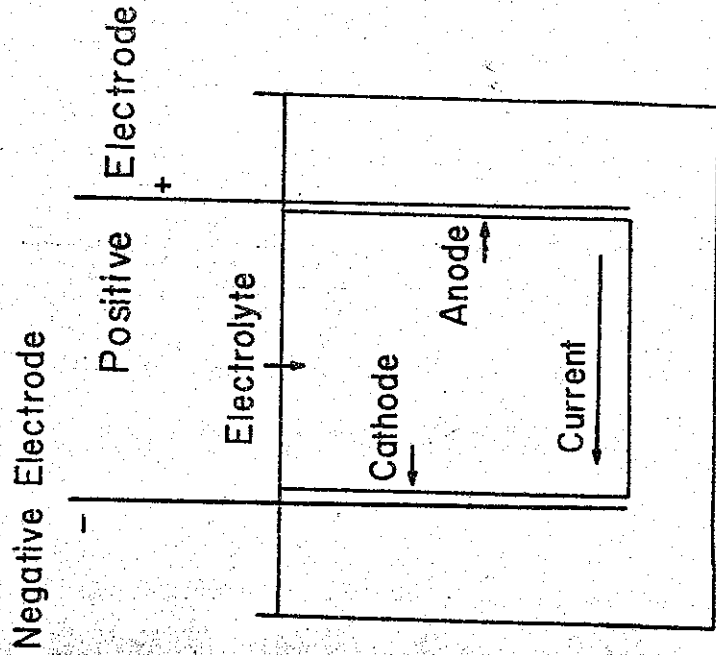

Origin of Electrochemical Nomenclature

The foregoing passage serves to remind us that Faraday did not possess our twentieth-century concept of an electrolyte, according to which positively and negatively charged cations and anions exist separately, whether in the solid crystal or in aqueous solution. To Faraday, the passage of the electric current was required to polarize the molecules, after which, by a series of successive decompositions and recompositions, the anions (say, oxygen atoms) went in one direction and the cations (say, hydrogen atoms) went in the other; when these atoms reached the boundaries of the solution adjacent to the electrodes, no further recombination could occur and the free elements were 'rendered', to use Faraday's word for it, at those places. To emphasize further that he wished to particularize the solution boundaries adjacent to the electrodes as functionally different from the electrodes themselves, Faraday wanted to distinguish them by specific terms: i.e. the anode and the cathode. The terms anode and cathode, therefore, were not for him, as they have become (by degeneration of meaning) for us, merely synonyms for the positive and negative electrodes respectively: they were to represent, in the phase containing the electrolyte, the actual phase surface in contact with the electrodes. The above diagram, the right hand part of which is based on a sketch inserted by Faraday in the margin of his own copy of the printed version of his 7th Series (45), makes his meaning clear.

The subsequent evolution of the concept of an electrolyte belongs rather to the history of science than to our present limited topic; a good account of it has been made by W. J. Hamer (46).

Although the new terminology had been published, both Faraday and Whewell at different times were tempted to make later revisions, regardless of the general experience that it is easier to gain acceptance for a totally new term than it is to modify one already delivered. The following letter from Whewell records a suggestion, fortunately abortive, to eliminate *ion* while retaining *anion* and *cation*.

Whewell to Faraday (47)

Trin. Coll. Cambridge

Dec. 3, 1834

My dear Sir,

I contrived to get off for Cambridge by Sunday evening's mail, and so did not come to see your devices on Monday which I wanted very much to do; but engagements must be kept and lectures given at the appointed time;—a scientific truth of which you have, I dare say, seen

the value before this time. If I had seen you I wanted to say a word in connexion with what you intimated, that you did not like the word *ion* as a general term for the two elements the anion and cation—or that your readers did not like it. You may recollect that at first I mentioned this as a term which I was not satisfied with. If you think it worth while to make the alteration, I would propose *stechion* 'element' as a general term which shall mean the anion and cation together. The Greek term (*στοιχείον*) is the proper word for 'element', and occurs in our derivative stoecheiometry, a word sometimes used in chemical literature; but the word *stechion*, the proper English form of it, is not used, and therefore you may introduce it in what sense you like. Moreover the derivation of *stechion* will sufficiently harmonize with anion and cation, which it is to put people in mind of, and so will keep them in their places.

Perhaps you will not think this suggestion of any importance. I do not say it is of much; but as it occurred to me I have sent it you. Many thanks for your eighth series.

Believe me,  
Yours truly,  
W. Whewell

A year later Whewell made another suggestion for a revision of one of the terms.

Whewell to Faraday (48)

Dec. 11, 1835

My dear Sir,

I think I told you that I was a little dissatisfied with the *cation* from its resemblance to the common termination of words which is made into *cayshion* in pronunciation. To avoid this I would recommend putting two dots over the i, *cat̄ion*. You might also allow *an̄ion* and *ion* in the same way, but there is not the same reason for this, though it would prevent your German translators from making your *ions* into *jons* as they do in Poggendorf. I am desirous your terms should be as unexceptionable as possible because you say you intend to use them freely, and it is easy to see how important are the purposes to which you and your successors will have to apply these terms . . . .

Faraday followed this suggestion at once, as can be seen in the 12 December entry in his Diary (49), but he did not persist with the usage.

Whewell added another correction in 1837 when, in his *History of the Inductive Sciences* he indicated his preference for *cath̄ion* (50): 'The analogy of

the Greek derivation requires cation; but to make the relation to *cathode* more obvious to the English reader, and to avoid a violation of the habits of English pronunciation, I should prefer *cathion*.

Thenceforth Faraday used *cathion* consistently (51), and Whewell used *cathion*. Other writers were, perhaps pardonably, confused: H. M. Noad, F.R.S. (52) wrote *ion* but omitted the diaeresis in *anion* and *cation*, which is a combination never put forth by Whewell. Even more confusion attended Faraday's distinction of the anode from the positive electrode: Noad (1839), wishing to emphasize the distinction still further, suggested *anelectrode* and *cathelectrode* for the positive and negative electrodes respectively; J. F. Daniell, F.R.S. suggested (1839) the terms *zincode* and *platinode*. Both these writers made it clear that their terms were *not* alternatives for anode and cathode: Daniell wrote (53): 'the anode is that surface of the electrolyte. . . which is in contact with the zincode'. The mistaken interpretation of *zincode* and *platinode* as alternatives for *anode* and *cathode* was, however, made almost at once, and first, interestingly enough, by Whewell (1840) in a passage already quoted (ref. 43). Alfred Smee, F.R.S., writing soon after, was equally misleading: he wrote (54): 'Dr Faraday, disapproving of the names of poles, has called the electro-negative the cathode; and Professor Daniell, disapproving of both, has called it the platinode.' G. W. Francis (1846) in his *Dictionary of the Arts and Sciences* (55) defines anode: 'The positive pole of a galvanic battery, as opposed to cathode the negative. The anode is called also the zincode.' What started as a mistake has now become accepted usage, especially as modern writers no longer need the original distinction that Faraday deemed necessary.

Even greater confusion has been introduced by attaching the terms *anode* and *cathode* to the poles of a voltaic, or primary cell. Faraday certainly never intended and almost certainly would never have approved this usage. It has led to endless trouble, as the anode, which is positive in the electrolytic cell, is negative in the voltaic cell. There is, in fact, not only no real need today for the terms anode and cathode in the sense that Faraday intended, but also in the sense in which they are now used. Simply to designate the poles of a voltaic cell or the electrodes of an electrolytic cell as either positive or negative would meet all present demands and clear away some quite unnecessary verbal puzzles that now obscure the subject for a beginner.

Of the other terms, Noad found only *electrode*, *electrolyze* and *electrolyte* completely free from objection; Faraday himself, as we have seen, anticipated only little use for *ion*. A generation later Tyndall (56) observed: 'All these terms [electrode, electrolysis, and electrolyte] have become current in

science. Faraday called the positive electrode the *Anode*, and the negative one the *Cathode* [this is not accurate as we have seen], but these terms, though frequently used, have not enjoyed the same currency as the others. The terms *Anion* and *Cation* . . . and the term *Ion* . . . are still less frequently employed.'

The advent of the theory of electrolytic dissociation (1887) restored the importance of the terms *anion*, *cation* and *ion*, which were then identified explicitly as bodies having a real physical existence in solution. As much of this later work was done in Germany, the revived *cation* was transferred back to its native country as *kation*. Writing in 1898, Silvanus Thompson noted (57): 'The words *cathode* and *cation* are now more usually spelled *kathode* and *kation*.' All variants, however, at least, in Britain and the United States, have long since been dropped in favour of the spelling as first given by Faraday in 1834. These words have also influenced later coinages of new terms: the termination *-on* taken from *ion* was also adopted for *electron*, thence for *proton*, *neutron*, *photon* and *positron*.

Whewell continued to be Faraday's sole adviser on all matters of nomenclature. On 12 October 1837, Faraday wrote to him (58): 'While on words I will merely mention some other cases where they are wanting. Perhaps at some time they may occur to you. One is sadly wanted to replace *current*; others for *Positive* and *Negative*; and some terms are required to express direction of the force or forces. If anode and cathode were to be received into use perhaps they would serve as bases: but something still more general and founded rather upon the word to be used instead of *current* would be better. I hope I am not annoying you with my fancies. If you feel fretted by me put my letter in the fire.'

Whewell was not at all fretted, as his reply indicates (59):

Trin. Coll., Cambridge,  
Oct. 14, 1837

My dear Sir,

I am always glad to hear of the progress of your researches, and never the less so because they require the fabrication of a new word or two. Such a coinage has always taken place at the great epochs of discovery; like the medals that are struck at the beginning of a new reign:—or rather like the change of currency produced by the accession of a new sovereign; for their value and influence consists in their coming into common circulation.

I am not sure that I understand the views which you are at present bringing into shape sufficiently well to suggest any such terms as you

think you want. I think that if I could have a quarter of an hour's talk with you I should probably be able to construct terms that would record your new notions, so far as I could be made to understand them, better than I can by means of letters: for it is difficult without question and discussion to catch the precise kind of relation which you want to express. . . . I do not catch your objection to *current*, which appears to me to be capable of jogging on very well from *cathode* to *anode*, or vice-versa. As for positive and negative, I do not see why *cathodic* and *anodic* should not be used, if they will do the service you want of them.

The continuation of their correspondence takes up the terms *dielectric*, *inductric*, *inducteous*, *diamagnetic* and *paramagnetic*. Whewell also added a long and scholarly essay *On the Language of Science* to his *Philosophy of the Inductive Sciences* (1840), the pages assigned to it being kept 'in a perfect foam of unpronounceable Greek, Latin, and German technical terms,' according to Sir John Herschel (60). This essay, which has not been reprinted since 1858, deserves a twentieth-century airing (61): the subject has a new significance and the need for principles, as well as good taste, in the expansion of scientific terminology is urgent. Whewell's essay, which is both the history and the philosophy of the language of science, is the first classic of its subject.

In this essay Whewell suggested some new words, two of which have met with such wide use (and abuse) that they are sometimes assumed to be Americanisms (62): they are, *scientist* and *physicist*. Faraday approved of the former, but not of the latter; he wrote, 20 May 1840 (63): 'I perceive also another new and good word, the *scientist*. Now can you give us one for the French physicien? *Physicist* is both to my mouth and ears so awkward that I think I shall never be able to use it. The equivalent of three separate sounds of *i* in one word is too much.' *Blackwood's Magazine* (64) was more emphatically disapproving: 'The word *physicist*, where four sibilant consonants fizz like a squib. . . .'

Once in his later years Whewell went to inspect the laying of a telegraph cable from England to Holland; he found the operator employed in testing, as he was told, the *conductivity* of the wire. The old clergyman was unusually gratified at receiving this information: the word, he told the busy young man, was one that he himself had recommended (65), and he was glad to learn that it had found its way into the working vocabulary of galvanism as an art (66). Today we can find many a word of Whewell's invention deeply rooted in the international language of science, and proving even more useful now than when first originated; each one bears the stamp of its author's scholarship, literary skill, imagination and common sense.

## NOTES

- (1) John Tyndall, *Faraday as a discoverer*, London, 1868, p. 54.
- (2) The Faraday-Whewell correspondence preserved at Trinity College Library consists of 42 letters from Faraday to Whewell, and 25 letters from Whewell to Faraday. The letters from Faraday came into the possession of the Library on Dr Whewell's death. The letters from Whewell were with Faraday's papers, which passed into the hands of Miss Jane Barnard, niece of Mrs Faraday. Miss Barnard left them by her will to Mr Blaikley, to be dealt with as he thought fit. Mr Blaikley considered Trinity College would be the appropriate home for the Whewell letters; they were presented by him in August 1914 and January 1916. Not all Whewell's letters to Faraday were in this collection, however: two had been placed by Faraday himself in an album that is now in the possession of the Royal Institution (see ref. 14); and two more, whose present whereabouts are unknown to me, were printed in 1898 by S. P. Thompson, ref. 4.
- (3) I. Todhunter, *William Whewell, an account of his writings, with selections from his literary and scientific correspondence*, London, 1876, 1, 46 and 89; 2, 178-183.
- (4) S. P. Thompson, *Michael Faraday, his life and work*, London, 1898, pp. 163-164 and pp. 205-206.
- (5) *Faraday's Diary*, G. Bell and Sons, Ltd, London, 1932, 2, between 272-273.
- (6) R. E. Oesper and M. Speter, *The Scientific Monthly*, 45, 535-546 (1937)
- (7) *A slight sketch of the life of the late Whitlock Nicholl, M.D.* Privately printed, London, 1841. More accessible, though less extensive, is W. Monk, *Roll of the Royal College of Physicians of London*, 2nd. Edition, London, 1878, 3, 149-151.
- (8) *The flow of clever nonsense*. . . . In the autumn of 1833 Mrs Nicholl's sister Caroline Hume married her cousin Mr Hassard Hume Dodgson, and at a meeting of the family that took place on that occasion Dr Nicholl became known to many of his wife's relations, who 'laughingly thanked Mrs Nicholl, for having brought among them so delightful a companion.' Dr Nicholl and the Rev. Charles Dodgson, the brother of Mr Hassard Dodgson and the father of 'Lewis Carroll', thereafter became intimate friends; some of their correspondence is to be found in ref. 7. This thread of kinship links two lovers of verbal nonsense: the one, the author of technical terms in medicine and science; the other—the author of *Jabberwocky*.
- (9) Account of a case of a curious imperfection of vision. *Med. Chir. Soc. Trans.*, 7, 477-481 (1816); Account of a case of defective powers to distinguish colours. *Med. Chir. Soc. Trans.* 9, 359-363 (1818); Remarks on a peculiar imperfection of vision with respect to colours. *Thomson's annals of philosophy, N.S.*, 3, 128-137 (1822).
- (10) *Trans. Assn. King's & Queen's Coll. Phys. Ireland*, 3, 177, 268 (1820).
- (11) R. Appleyard, *A tribute to Michael Faraday*, London, 1931, p. 191.
- (12) Original in the Royal Society.
- (13) Reference (7), pp. 112-113. The letter is dated 'Royal Institution, January 23, 1839'.
- (14) Not previously published; original in the Royal Institution. Faraday compiled an album of engraved portraits of some of his more eminent correspondents, which he further illustrated by inserting opposite to each one an autograph letter from the person concerned. The portrait of Dr Nicholl in Faraday's album is a copy of the engraving used as the frontispiece of reference (7), and is reproduced here. The portrait of Dr Whewell in Faraday's album is a lithograph copy of a drawing by E. U. Eddis, published in 1835, which is also reproduced here.
- (15) M. Faraday, *Experimental researches in electricity*, London, 1839, 1, §60.

- (16) Ref. 4, p. 116. Faraday's original letter to Phillips is now in the Burndy Library, Norwalk, Conn. Sec B. Dibner, *Faraday discloses electro-magnetic induction*, New York, 1949.
- (17) Ref. 15, I, §481.
- (18) *Ibid.*, I, §524.
- (19) *Ibid.*, I, §§465-471.
- (20) *Ibid.*, I, §§497-498.
- (20A) Ampère had earlier expressed dissatisfaction with the term *poles* and had substituted *rheophores* ( $\rho\acute{\epsilon}\omicron\varsigma$ , flow i.e. current +  $\phi\acute{\omicron}\rho\omicron\varsigma$ , bearing); but he did so for reasons of pure logic rather than because he had any new experimental facts to offer. The following explanation of Ampère's reasoning is taken from *A manual of electro dynamics, chiefly translated from the Manuel d'électricité dynamique of J. F. Demouferrand* by James Cumming, Cambridge, 1827, pp. 6-7.

'It has been usual to designate the opposite ends of the pile, and the wires attached to them, as its *poles*, which seems objectionable, both as an improper term in itself and as founded upon false analogies. In Geometry, the poles of a circle are two points in a line drawn perpendicular to its plane and passing through its centre: the word is used, with the same signification, in Astronomy, the poles of a planet being merely the poles of its equator; hence the same name has been given to those two ends of a magnet which turn towards the poles of the earth. But there can be no such reason for applying this term to the extremities of a Voltaic pile; and it would be attended with this anomaly, that in the case of a circular conductor, the poles, being the points of exit and entrance of the current, would be two points in the circle itself, and consequently very different from its geometrical poles. As the attaching such different significations to the same word must, unavoidably, produce confusion and obscurity in the explanation of the phenomena, Ampère has proposed to avoid this inconvenience, by giving the name of *Rheophores* to the two portions of conductors attached to the ends of the pile, when employed in electro-dynamics; in analogy with the term *electrophorus*, which has been similarly applied in electrostatics. This expression will therefore be adopted in this treatise; the positive rheophorus being that which, in the interrupted circuit, would exhibit the positive or vitreous electricity; and the negative that which is at the other extremity of the pile.

'The names of positive and negative rheophorus are substituted for those of copper and zinc, to avoid the confusion which has arisen from designating the ends of the pile by their respective metals: for, in consequence of the current being from the copper to the zinc, or *vice-versâ*, accordingly as the series is terminated by single or double plates, many English authors have used the expressions copper and zinc, as applied to the extremities of the pile, in a sense exactly the reverse of the continental writers.'

- (21) The difficulty posed by Faraday's hand-writing has led to more than one version of some of these words. In Faraday's Diary (ref. 5, pp. 183-184) the versions given are *electrobeid* and *cisode* as read by T. Martin. Bence-Jones, who had access to the Diaries for his *Life and letters of Faraday* (London, 1870) gave *electroleid* and *eisode*, (*op. cit.* 2, 38). Todhunter (ref. 3, 2, 179) gave *eisode*, read from Whewell's hand-writing. There is no obvious etymology for *cisode*.
- (22) Ref. 15, I, §667.
- (23) *Ibid.*, I, §283.

- (24) A biography of Willis, written by his nephew J. Willis Clark, is in the *Dictionary of National Biography*, 62, 21-23 (1900).
- (25) Willis's book is credited with having turned Ruskin's attention to architecture, culminating in the writing of *Stones of Venice*, 1851-53. See *The Diaries of John Ruskin*, Oxford University Press, 1956, I, 321. Also see Ruskin's *Works*, ed. Cook and Wedderburn, London, 1903, 8, xl, for an account of Ruskin's visit to Cambridge in 1851, where he was entertained by Whewell and Willis.
- (26) Charles Lyell, *Principles of geology*, John Murray, London, 1833, 3, 53. Lyell's note on these words is worth reprinting: 'In the terms Pliocene, Miocene, and Eocene, the Greek diphthongs *ei* and *ai* are changed into the vowels *i* and *e*, in conformity with the idiom of our language. Thus we have Encenia, an inaugural ceremony, derived from *ἐν* and *καυνός*, recens; and as examples of the conversion of *ei* into *i*, we have icosahedron. I have been much indebted to my friend, the Rev. W. Whewell, for assisting me in inventing and anglicizing these terms, and I sincerely wish that the numerous foreign diphthongs, barbarous terminations, and Latin plurals, which have been so plentifully introduced of late years into our scientific language, had been avoided as successfully as they are by French Naturalists, and as they were by the earlier English writers, when our language was more flexible than it is now. But while I commend the French for accommodating foreign terms to the structure of their own language, I must confess that no naturalists have been more unscholarly in their mode of fabricating Greek derivatives and compounds, many of the latter being a bastard offspring of Greek and Latin.'
- (27) W. Whewell, *Architectural notes on German churches, with remarks on the origin of Gothic Architecture*. Cambridge, 1830, pp. xxxi-xxxiv.
- (28) *Ibid.*, pp. xxv-xxvi.
- (29) Ref. 3, I, 307-308.
- (30) For biographical information see Ref. 3; also Mrs Stair Douglas, *The life and selections from the correspondence of William Whewell*, London, 1881; Leslie Stephen, *Dictionary of National Biography*, 60, 454-463 (1899); J. Willis Clark, *Old friends at Cambridge and elsewhere*, London, 1900, pp. 1-76.
- (31) The Bridgewater Treatises were commissioned in 1830 by the President of the Royal Society (Davies Gilbert), under the terms of the will of the Earl of Bridgewater, who bequeathed a fund for the production of a series of treatises 'on the Power, Wisdom and Goodness of God as manifested in the Creation'. The Treatises were the last serious effort to provide a direct teleological interpretation of Nature.
- (32) A. M. Stoddart *John Stuart Blackie*, London, 1895, 2, 315.
- (33) Ref. 6, p. 539; original in Trinity College Library.
- (34) Faraday implies here that conduction of electricity through an electrolyte can take place without simultaneous electrolysis. This question later became the subject of a controversy between Foucault and Buff (1853). Modern theory would not support Faraday's opinion: see A. J. Berry, *From classical to modern chemistry*, Cambridge University Press, 1954, pp. 59-60.
- (35) Ref. 3, 2, 177-181; Ref. 6, pp. 540-542; original in Trinity College Library.
- (36) Ref. 6, pp. 542-543; original in Trinity College Library.
- (37) Ref. 3, 2, 181-183; Ref. 6, pp. 543-544; original in Trinity College Library.
- (38) Not previously published: original in Trinity College Library.
- (39) Ref. 5, 2, between 272-273; Ref. 6, pp. 544-545; original in the Royal Institution Library.

- (40) Ref. 4, pp. 145-146; Ref. 6, p. 545; original in Trinity College Library.
- (41) The meeting at Kensington refers to one of the Soirées of the Royal Society, held at Kensington Palace when H.R.H. the Duke of Sussex was President of the Society. The Soirée of 10 May 1834, is historically noteworthy as the occasion when G. B. Airy, F.R.S., was approached by the Duke of Sussex, on the part of the Government, about taking the office of Astronomer Royal; see Airy's *Autobiography*, Cambridge, 1896, p. 103.
- (42) Not previously published; original in Trinity College Library.
- (43) W. Whewell, *The Philosophy of the inductive sciences*, London, 1840, I, xcvi.
- (44) Ref. 15, I, §§661-663.
- (45) Ref. 4, p. 145, Fig. 12.
- (46) W. J. Hamer (ed.), *The structure of electrolytic solutions*, Wiley and Sons, New York, 1959, pp. 1-8.
- (47) Not previously published; original in Trinity College Library.
- (48) Not previously published; original in Trinity College Library.
- (49) Ref. 5, 2, 419.
- (50) W. Whewell, *History of the inductive sciences*, London, 1837, 3, 166.
- (51) See for example, his collected edition of *Experimental researches in electricity*, I, London, 1839, in which the Index (1839) reference is 'cations or cathions', although the textual references given, which ante-date 1837, show only *cation*. Later references (not indexed) in the same volume (e.g. §1650 of Feb. 1838) read *cathion*.
- (52) Henry M. Noad, *A course of eight lectures on electricity, Galvanism, magnetism, and electro-magnetism*, London, 1839, pp. 148-149.
- (53) J. F. Daniell, *An introduction to chemical philosophy*, London, 1839, pp. 445 and 449.
- (54) Alfred Smee, *Elements of electro-metallurgy*, 2nd. edition, London, 1843, p. 41.
- (55) G. W. Francis, *The dictionary of the arts, sciences and manufactures*, London, 1846.
- (56) Ref. 1, p. 55.
- (57) Ref. 4, p. 143.
- (58) Not previously published; original in Trinity College Library.
- (59) Ref. 4, p. 205.
- (60) Sir John F. W. Herschel, *Essays from the Edinburgh and Quarterly Reviews*, London, 1857, p. 254.
- (61) Whewell's last revision of his *Essay on the language of science* was published as a portion of his *Novum organon renovatum*, London, 1858, pp. 257-370.
- (62) 'Scientist has often been branded as an "ignoble Americanism" or "a cheap and vulgar product of trans-Atlantic slang"... Whoever objects to such words as *scientist* on the plea that they are not correct Latin formations, would have to blot out of his vocabulary such well-established words as *suicide*, *telegram*, *botany*, *sociology*, *tractarian*, *vegetarian*, *facsimile* and *orthopedic*; but then, happily, people are not consistent.' O. Jespersen, *Growth and structure of the English language*, Blackwell, Oxford, 1938, §121.
- (63) Not previously published; original in Trinity College Library.
- (64) *Blackwood's Magazine*, 1843, 54, 524.
- (65) See Ref. 43, p. cxiii: 'It is quite intolerable to have words regularly formed in opposition to the analogy which their meaning offers; as when bodies are said to have *conductibility* or *conducibility* with regard to heat. The bodies are *conductive* and their property is *conductivity*.'
- (66) The incident is related by Whewell in a letter to J. D. Forbes, 2 August 1862, Ref. 3, 2, 426.